



Installation of single switches with safety functions

- Use **only** switches with the symbol  (see figure on the side).
- Connect the safety circuit to **the NC normally closed contacts (11-12, 21-22 or 31-32)**.
- **The NO normally open contacts (13-14, 23-24, 33-34)** should be used **only for signalling**; these contacts are not to be connected with the safety circuit. However, if in the same protection two or more switches are used, it is possible to connect the contact NO to the safety circuit. In this case at least one of the two switches must have a positive opening and a normally closed contact NC (11-12, 21-22 or 31-32) must be connected to the safety circuit.
- Actuate the switch **at least up to the positive opening travel** shown in the travel diagrams with symbol .
- Operate the switch **at least with the positive opening force**, indicated between brackets below each article, aside the minimum force value.
- The fixing of the device must occur in compliance with the standard EN ISO 14119.

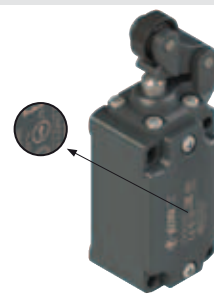

Whenever the machine guard is opened and during the whole opening travel, **the switch must be pressed directly** (fig. 1) **or through a rigid connection** (fig. 2).

Only in this way the positive opening of the NC normally closed contacts (11-12, 21-22, 31-32) is guaranteed.

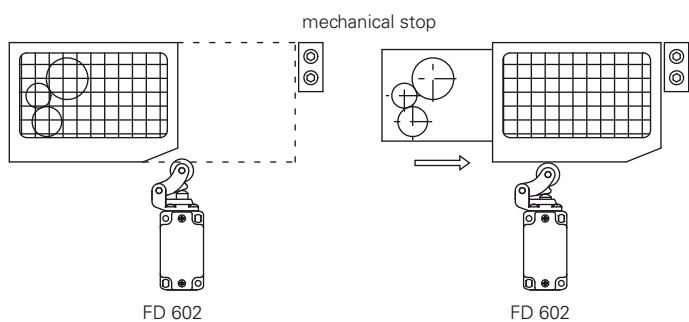

Fig.1

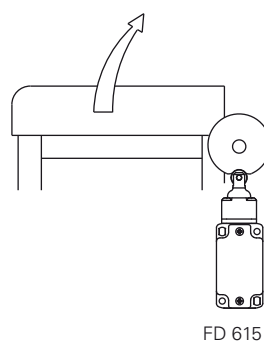
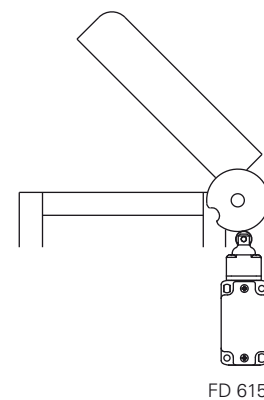

Fig.2



FD 615

In safety applications with only one switch for each guard, the switches **must never be activated by a release** (fig. 3 and 4) **or through a non rigid connection** (i.e. by a spring).

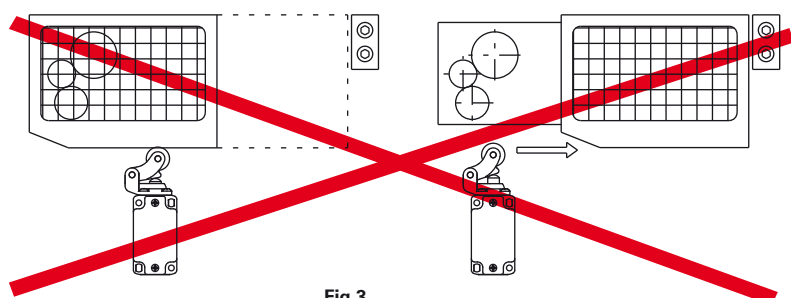

Fig.3

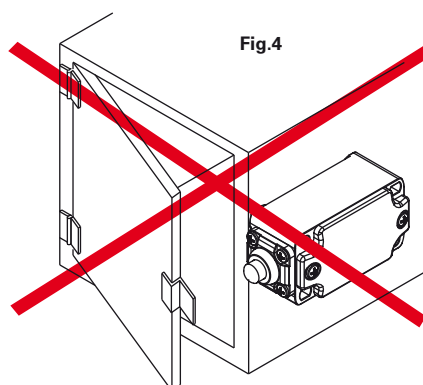
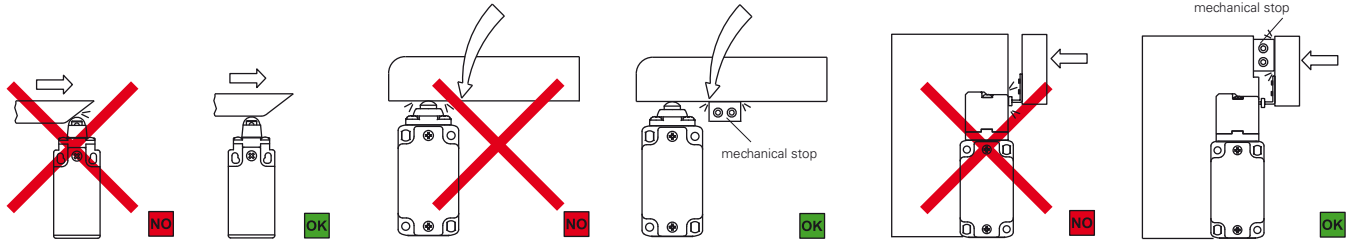

Fig.4

Mechanical stop

Acc. to EN ISO 14119 paragraph 5.2 letter h) "the position sensors must not be used as mechanical stop"



The actuator must not exceed the max. travel as indicated in the travel diagrams.

The guard must not make a mechanical stop on the switch head.

The actuator must not strike directly against the switch head.

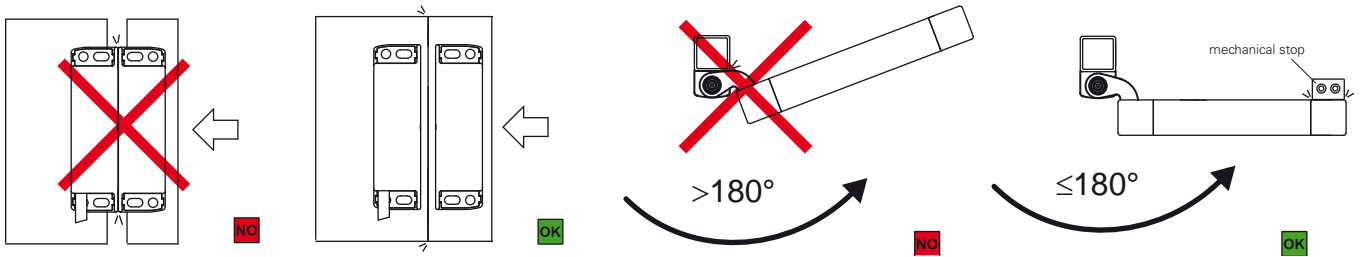

The actuator must not strike directly against the magnetic sensor.

The opening angle of safety hinge switch HP and HC series must not exceed 180°.

Actuation modes

Recommended application	Application to avoid <small>Possible application but with mechanical stress for the switch higher than expected, mechanical endurance is not guaranteed</small>	Forbidden application

Switches for heavy duty applications

Maximum and minimum actuation speed (FD-FL-FP-FC series)

Roller lever - Type 1

φ	Vmax (m/s)	Vmin (mm/s) L	Vmin (mm/s) R
15°	2,5	9	
30°	1,5	8	0,07
45°	1	7	
60°	0,75	7	

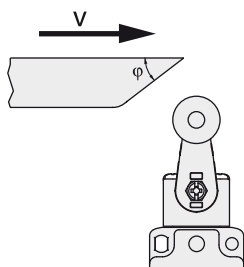

Roller plunger - Type 2

φ	Vmax (m/s)	Vmin (mm/s) L	Vmin (mm/s) R
15°	1	4	0,04
30°	0,5	2	0,02
45°	0,3	1	0,01

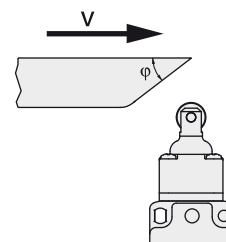

Roller lever - Type 3

φ	Vmax (m/s)	Vmin (mm/s) L	Vmin (mm/s) R
15°	1	5	0,05
30°	0,5	2,5	0,025
45°	0,3	1,5	0,015

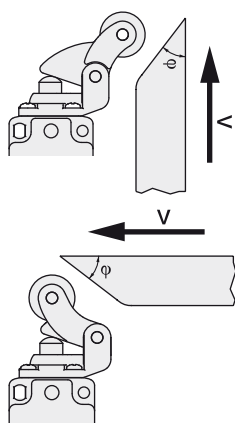

Plunger - Type 4

Vmax (m/s)	Vmin (mm/s) L	Vmin (mm/s) R
0,5	1	0,01

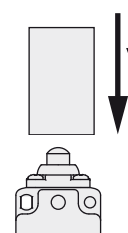

Contact type:

R = snap action
L = slow action

Tightening torques FD-FL-FP-FC-FG-FS-NG series

Cover screws **1**

0.8 ... 1.2 Nm

Head screws **2**

0.8 ... 1.2 Nm

Lever screw **3**

0.8 ... 1.2 Nm

Protection caps **4** (conduit entry M20/PG13.5)

1.2 ... 1.6 Nm

(conduit entry M16/PG11)

1 ... 1.4 Nm

Contact block screws **5**

0.6 ... 0.8 Nm

M5 body fixing screws

(with washer for FS series) **6**

2 ... 3 Nm

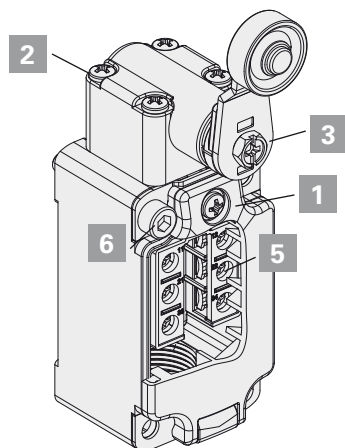

FD-FL-FC-FP

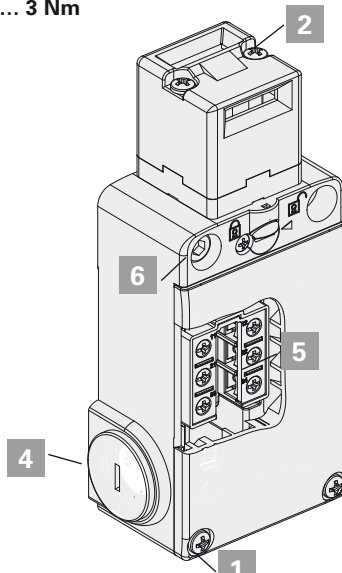



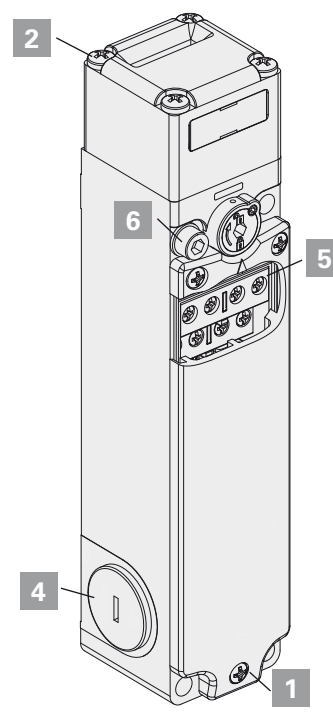









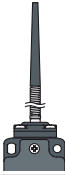

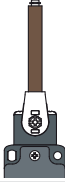





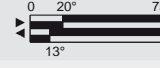
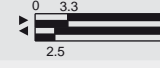



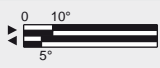
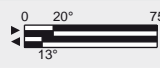
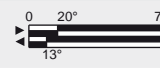
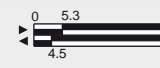

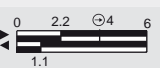

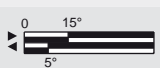
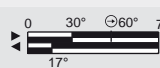



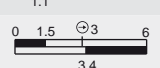
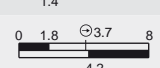

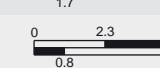



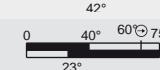



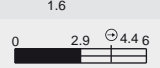
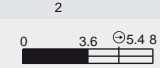
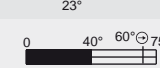
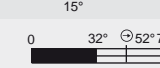

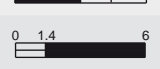
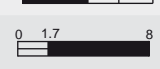
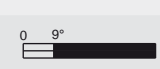

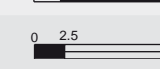

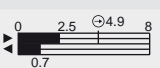
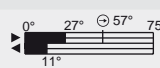

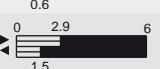
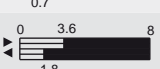
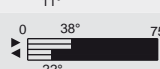

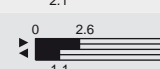

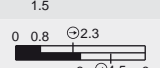
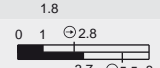
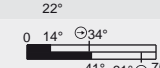



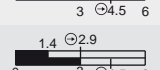
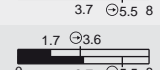

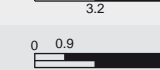

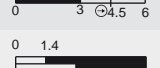
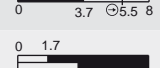

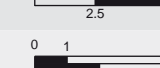

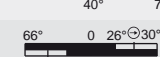

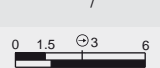
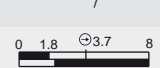



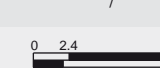

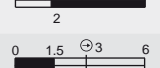
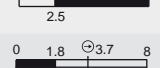
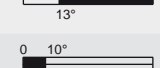

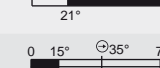
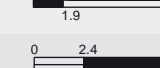

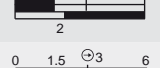
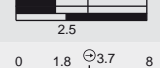
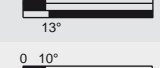

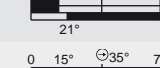
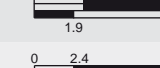

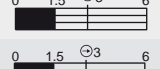
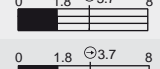
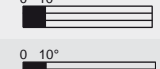

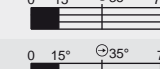
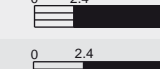

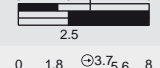



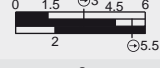
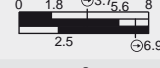



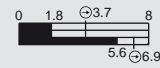
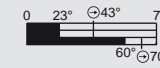

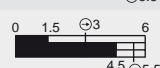

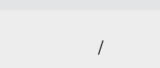
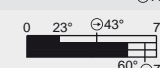

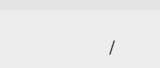

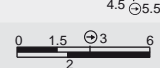
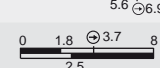

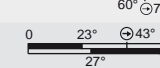

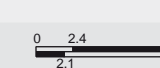

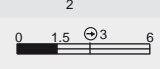
FS

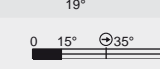



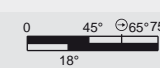
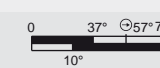

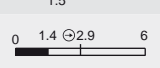
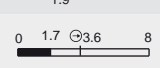
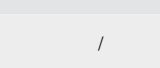
FG-NG

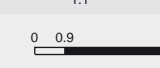
Switches for heavy duty applications FD-FL-FP-FC series

Travel diagrams

							
Contact blocks		Group 1	Group 2	Group 3	Group 4	Group 5	Group 6 inverted contacts
2 2x(1NO-1NC)							
3 1NO-1NC							
5 1NO+1NC							
6 1NO+1NC				/			
7 1NO+1NC				/			
9 2NC				/			
10 2NO							
11 2NC				/		/	
12 2NO				/			
13 2NC				/			
14 2NC				/			
15 2NO				/			
16 2NC		/	/	/		/	/
18 1NO+1NC							
20 1NO+2NC							
21 3NC							
22 2NO+1NC							
28 1NO+2NC				/			/
29 3NC				/			/
30 3NC				/			/
33 1NO+1NC							
34 2NC							
37 1NO+1NC				/			
66 1NC				/			
67 1NO							

Legend

 Closed contact |
  Open contact |
  Positive opening travel acc. to EN 60947-5-1 |
  Pushing the switch /
  Releasing the switch

Switches for normal duty applications

Maximum and minimum actuation speed (FR-FM-FX-FZ-FK series)

Roller lever - Type 1

φ	Vmax (m/s)	Vmin (mm/s)	
		L	R
15°	2,5	9	0,07
30°	1,5	8	
45°	1	7	
60°	0,75	7	

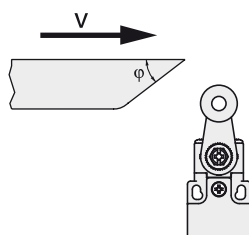

Roller plunger - Type 2

φ	Vmax (m/s)	Vmin (mm/s)	
		L	R
15°	1	4	0,04
30°	0,5	2	0,02
45°	0,3	1	0,01

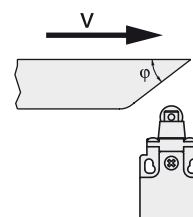

Roller lever - Type 3

φ	Vmax (m/s)	Vmin (mm/s)	
		L	R
15°	1	5	0,05
30°	0,5	2,5	0,025
45°	0,3	1,5	0,015

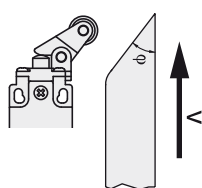

Plunger - Type 4

Vmax (m/s)	Vmin (mm/s)	Vmin (mm/s)
	L	R
0,5	1	0,01

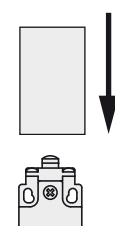

Contact type:

R = snap action
L = slow action

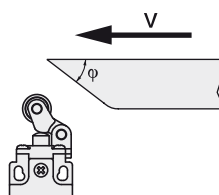

Roller plunger - Type 5

φ	Vmax (m/s)	Vmin (mm/s)	
		L	R
15°	0,3	4	0,04
30°	0,2	2	0,02

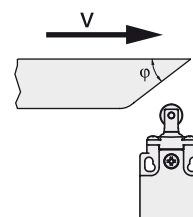

Tightening torques (FR, FX, FK and FW series)

Cover screws 1	0.7 ... 0.9 Nm
Head screws 2	0.5 ... 0.7 Nm
Lever screw 3	0.7 ... 0.9 Nm
Protection caps 4 (conduit entry M20/PG13.5)	1.2 ... 1.6 Nm
(conduit entry M16/PG11)	1 ... 1.4 Nm
Contact block screws 5	0.6 ... 0.8 Nm
M4 body fixing screws (with washer for FR-FK series) 6	2 ... 3 Nm
M5 body fixing screws (with washer for FW series) 7	2 ... 3 Nm

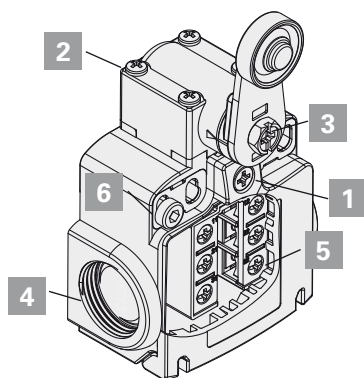

FR-FX-FK-FM-FZ

Tightening torques (FM and FZ series)

Cover screws 1	0.8 ... 1.2 Nm
Head screws 2	0.8 ... 1.2 Nm
Lever screw 3	0.8 ... 1.2 Nm
Protection caps 4 (conduit entry M20/PG13.5)	1.2 ... 1.6 Nm
(conduit entry M16/PG11)	1 ... 1.4 Nm
Contact block screws 5	0.6 ... 0.8 Nm
M4 body fixing screws 6	2 ... 3 Nm

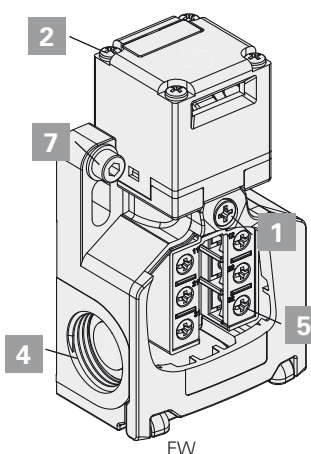

FW

Switches for normal duty applications (FR-FM-FX-FZ-FK series)

Travel diagrams

Contact blocks	Group 1	Group 2	Group 3	Group 4	Group 5	Group 6	Group 7 inverted contacts
2 2x(1NO-1NC) 							
3 1NO-1NC 							
5 1NO+1NC 							
6 1NO+1NC 				/			
7 1NO+1NC 				/			
9 2NC 				/			
10 2NO 							
11 2NC 				/		/	
12 2NO 							
13 2NC 				/			
14 2NC 				/			
15 2NO 				/			
16 2NC 	/	/	/	/		/	/
18 1NO+1NC 							
20 1NO+2NC 							
21 3NC 							
22 2NO+1NC 							
28 1NO+2NC 				/			
29 3NC 				/			
30 3NC 				/			
33 1NO+1NC 							
34 2NC 							
37 1NO+1NC 				/			
66 1NC 							
67 1NO 							

Legend

Closed contact |
 Open contact |
 Positive opening travel acc. to EN 60947-5-1 |
 Pushing the switch /
 Releasing the switch

Switches with reset W3 for normal duty applications, FR-FM-FX-FZ-FK series

Travel diagrams

Contact blocks		Group 1	Group 2	Group 3	Group 4
6 1NO+1NC					
9 2NC					
10 2NO					
20 1NO+2NC					
21 3NC					
22 2NO+1NC					
33 1NO+1NC					
34 2NC					
2 2x(1NO-1NC)					

Legend

Closed contact |
 Open contact |
 Positive opening travel acc. to EN 60947-5-1 |
 Pushing the switch /
 Releasing the switch |
 R travel for reset attachment

Prewired switches FA series

Travel diagrams

Contact blocks		Group 1	Group 2	Group 3	Group 4
41 1NO+1NC					
45 1NO+1NC					
46 1NO+1NC					
48 1NO+1NC					

Legend

Closed contact |
 Open contact |
 Positive opening travel acc. to EN 60947-5-1 |
 Pushing the switch /
 Releasing the switch

Switches for safety applications, FR-FM-FX-FZ-FK-FW series

Travel diagrams

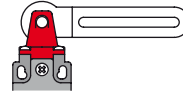

Contact blocks	Group 8	Group 9	Group 10	Group 11
5 1NO+1NC 				
6 1NO+1NC 				
7 1NO+1NC 			/	/
9 2NC 				
11 2NC 		/	/	/
13 2NC 		/	/	/
14 2NC 			/	/
18 1NO+1NC 				
20 1NO+2NC 				
21 3NC 				
22 2NO+1NC 				
33 1NO+1NC 				
34 2NC 				
37 1NO+1NC 		/	/	/
66 1NC 				

Legend

Closed contact |
 Open contact |
 Positive opening travel acc. to EN 60947-5-1 |
 Pushing the switch /
 Releasing the switch

Modular prewired switches (NA-NB-NF series)

Maximum and minimum actuation speed

Roller lever - Type 1

φ	Vmax (m/s)	Vmin (mm/s) L	Vmin (mm/s) R
15°	2,5	9	0,07
30°	1,5	8	
45°	1	7	
60°	0,75	7	

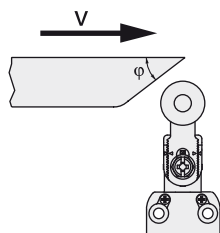

Roller plunger - Type 2

φ	Vmax (m/s)	Vmin (mm/s) L	Vmin (mm/s) R
15°	1	4	0,04
30°	0,5	2	0,02
45°	0,3	1	0,01

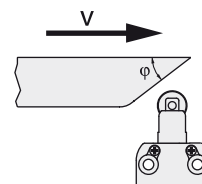

Roller lever - Type 3

φ	Vmax (m/s)	Vmin (mm/s) L	Vmin (mm/s) R
15°	1	5	0,05
30°	0,5	2,5	0,025
45°	0,3	1,5	0,015

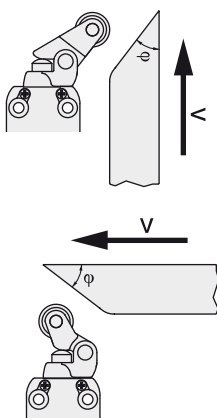

Plunger - Type 4

Vmax (m/s)	Vmin (mm/s) L	Vmin (mm/s) R
0,5	1	0,01

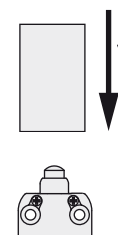

Roller plunger - Type 5

φ	Vmax (m/s)	Vmin (mm/s) L	Vmin (mm/s) R
15°	0,3	4	0,04

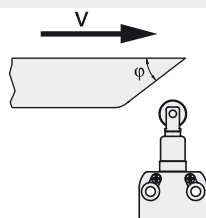

Contact type:

R = snap action
L = slow action

Screw tightening torques

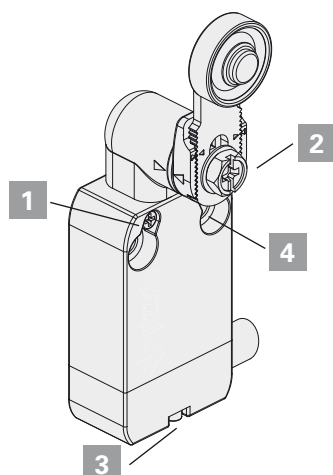

For NA and NB series:





Head screws **1** **0.5 ... 0.7 Nm**
Lever screws **2** **0.8 ... 1.2 Nm**
Connector screw **3** **0.3 ... 0.6 Nm**
M4 body fixing screws **4** **2 ... 3 Nm**

For NF series:



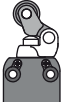

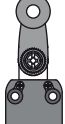
Head screws **1** **0.3 ... 0.4 Nm**
Lever screws **2** **0.8 ... 1.2 Nm**
Connector screw **3** **0.2 ... 0.3 Nm**
M4 body fixing screws **4** **2 ... 3 Nm**

Modular prewired switches (NA-NB-NF series)

Travel diagrams

						
Contact blocks	Group 1	Group 2	Group 3	Group 4	Group 5	Group 6
B11 1NO+1NC						
B02 2NC						
B12 1NO+2NC						
B22 2NO+2NC						
G11 1NO+1NC				/		
G02 2NC						
G12 1NO+2NC				/		
G22 2NO+2NC				/		
H11 1NO+1NC						
H12 1NO+2NC						
H22 2NO+2NC						
L11 1NO+1NC						
L12 1NO+2NC						
L22 2NO+2NC						
BA1 1NO+1NC in deviation						

Legend

 Closed contact |
  Open contact |
  Positive opening travel acc. to EN 60947-5-1 |
  Pushing the switch /
  Releasing the switch

Microswitches MK series

Maximum and minimum actuation speed

Plunger - Type 1

Vmax (m/s)	Vmin (mm/s)
0,5	0,05

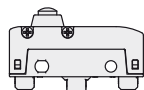

Roller plunger - Type 2

φ	Vmax (m/s)	Vmin (mm/s)
15°	0,6	0,2
30°	0,3	0,1
45°	0,1	0,05

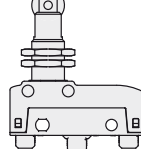
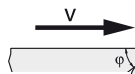

Lever with direct action (D) - Type 3

Vmax (m/s)	Vmin (mm/s)
0,03 x L	0,0166 x L

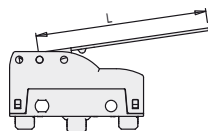

Lever with inverted action (R) - Type 4

Vmax (m/s)	Vmin (mm/s)
0,015 x L	0,0083 x L

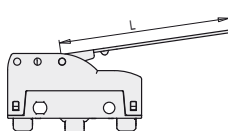

Lever with back direct action (F) - Type 5

Vmax (m/s)	Vmin (mm/s)
0,01 x L	0,0047 x L

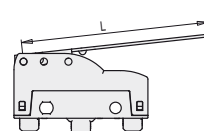

Roller lever with direct action (D) - Type 6

φ	Vmax (m/s)	Vmin (mm/s)
15°	0,1 x L	0,0664 x L
30°	0,05 x L	0,0332 x L
45°	0,03 x L	0,0166 x L

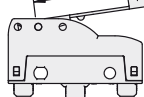
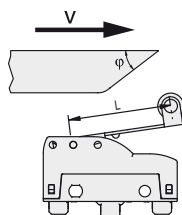

Roller lever with inverted action (R) - Type 7

φ	Vmax (m/s)	Vmin (mm/s)
15°	0,048 x L	0,0332 x L
30°	0,024 x L	0,0166 x L
45°	0,015 x L	0,0083 x L

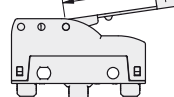
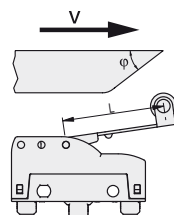

Roller lever with back direct action (F) - Type 8

φ	Vmax (m/s)	Vmin (mm/s)
15°	0,032 x L	0,0188 x L
30°	0,016 x L	0,0094 x L
45°	0,01 x L	0,0047 x L

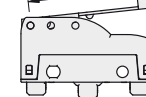
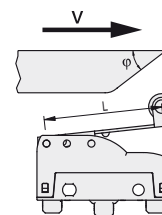

Tightening torques

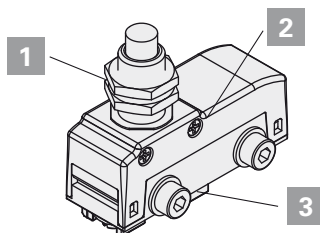

Tighten the nuts **1** with a torque of **2 ... 3** Nm.
Tighten the head screws **2** with a torque of **0.3 ... 0.4** Nm.

Tighten the M4 screws **3** with a torque of **0.8 ... 1.2** Nm, insert washer.

Attention: A tightening torque higher than 1.2 Nm can cause the breaking of the microswitch.

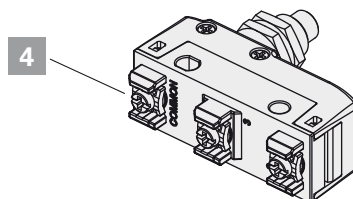

Tighten the terminal screws **4** with a torque of **0.6 ... 0.8** Nm.

General prescriptions

The device is designed to be installed on industrial machineries.

The installation must be performed only by qualified staff aware of the regulations in force in the country of installation.

The device must be used exactly as supplied, properly fixed to the machine and wired.

It is not allowed to disassemble the product and use only parts of the same, the device is designed to be used in its assembly as supplied. It is prohibited to modify the device, even slightly e.g.: replace parts of it, drill it, lubricate it, clean it with gasoline or gas oil or any aggressive chemical agents.

The protection degree of the device refers to the electrical contacts only. Carefully evaluate all the polluting agents present in the application before installing the device, since the IP protection degree refers exclusively to agents such as dust and water according to EN 60529. Thus the device may not be suitable for installation in environments with dust in high quantity, condensation, humidity, steam, corrosive and chemical agents, flammable or explosive gas, flammable or explosive dust or other polluting agents.

Some devices are provided with a perforated housing for inserting the wires. In order to guarantee an adequate protection degree of the device, the wiring through the hole must be done with an appropriate sealing that prevents polluting agents from entering. For a correct wiring then the cable glands, fittings, connectors and other means must have the IP protection degree according to EN 60529 equal to or higher than the one of the device.

Store the products in their original packaging, in a dry place with temperature between -40° C and +70°C

Failure to comply with these requirements or incorrect use during operation can lead to the damage of the device and the loss of the function performed by the device itself. This entails the cessation of the warranty on the item and relieves the manufacturer of any liability.

Device utilization

- Before use, check if the national rules provide for further requirements in addition to those given here.
- Before installation, make sure the device is not damaged in any part.
- All devices are designed to be operated by moving parts of industrial machines.
- Do not use the device as mechanical stop of the actuator.
- Do not apply excessive force to the device once it has reached the end of its actuating travel.
- Do not exceed the maximum actuation travel.
- Avoid contact with corrosive fluids.
- Do not stress the device with bending and torsion.
- Do not disassemble or try to repair the device, in case of defect or fault replace the whole device.
- In case the device is deformed or damaged replace it completely. There is no guarantee of working for a deformed or damaged device.
- Always attach the following instructions in the manual of the machine where the device is installed
- The preservation of the following instructions for use has to allow their consultation for the whole utilization period of the device.

Wiring and installation

- The installation has to be made by qualified staff.
- Limit the use of these devices to control functions.
- Observe minimum distances between devices (if provided).
- Comply with the tightening torques indicated in this catalogue.
- Keep the electrical load below the value specified by the respective utilization category.
- Turn off the power before access to the contacts, also during the wiring.
- Do not paint or varnish the devices.
- It is possible to install the product only on flat and clean surfaces.
- Do not bend or deform the device during installation.
- Do not use the device as a support for other parts of the machine (e.g. wireways, conduits, etc.)
- The device must be fixed to the machine through the holes provided on the housing. The device must be fixed with screws of adequate length and resistance to the expected stress. At least two screws must be used to fix the housing to the machine.
- After and during the installation do not pull the electrical cables connected to the device. If high traction is applied to the cables (not supported by an appropriate cable gland) the device contact block may be damaged.
- During wiring comply with the following requirements:
 - Comply with the minimum and maximum sections of electrical conductors admitted by terminals (if present).
 - Tighten the electrical terminals with the torque indicated in this catalog (if present).
- Do not introduce polluting agents into the device as: talc, lubricants for cable sliding, powder separating agents for multipolar cables, small strands of copper and other pollutants that could affect the proper functioning of the device.
- Before closing the device cover (if present) verify the correct positioning of the

gaskets.

- Verify that the electrical cables, terminals, cable numbering systems and any other part do not obstruct the cover from closing correctly or if pressed between them do not damage or compress the internal contact block.
- For the device with integrated cable the free end of the cable must be properly connected inside a protected housing. The electrical cable must be properly protected from cuts, impacts, abrasion, etc.
- After the installation and before commissioning of the machine, verify:
 - the correct operation of the device and all its parts;
 - the correct wiring and tightening of all screws;
 - the actuating travel of the actuator is shorter than the maximum travel allowed by the device.
- After installation, periodically check for correct device operation.

Do not use in the following environments:

- Environment where dust and dirt can cover the device and by sedimenting stop its correct working.
- Environment where sudden changes of temperature cause condensation.
- Environment where ice formation on the device is possible.
- Environment where the application causes knocks or vibrations which can damage the device.
- Environment with presence of explosive and inflammable gas or dust.

Utilization limits

- Use the devices following the instructions, complying with their working limits and the standards in force.
- The devices have specific application limits (min. and max. ambient temperature, mechanical endurance, protection degree, utilization categories, etc.). These limits are satisfied by the different devices only if singularly taken and not in combination among them. For further information contact our technical department.
- The utilization implies compliance and acknowledgement of the following standards: EN 60204-1, EN 60947-5-1, ISO 12100, EN ISO 14119.
- Contact our Technical dept. for information and assistance (phone +39.0424.470.930 / fax +39.0424.470.955 / e-mail tech@pizzato.com) in the following cases:
 - Cases not mentioned on the following instructions.
 - In nuclear power stations, trains, airplanes, cars, buses, incinerators, medical devices or any application where the safety of two or more persons depend on the correct operation of the device.

Additional prescription for safety applications

Provided that all previous requirements for the devices installed for safety application are fulfilled, further additional prescriptions have to be observed:

- The utilization in any case implies compliance and acknowledgement of the following standards: IEC 60204-1, IEC 60947-5-1, ISO 12100, EN ISO 14119, EN 62061, EN ISO 13849-1, EN ISO 13850.
- Always connect the protection fuse (or equivalent device) in series with the NC contacts of the safety circuit.
- Periodically verify the correct working of the safety devices, the periodicity of this verification is settled by the machine manufacturer based on the machine danger degree and it doesn't have to be less than one a year.
- After the installation and before commissioning of the machine, verify:
 - the correct operation of the device and all its parts;
 - the correct wiring and tightening of all screws;
 - the actuating travel of the actuator is shorter than the maximum travel allowed by the device.
- When the device is installed with safety functions, the duration of its use is limited. After 20 years from the date of manufacture, the device must be replaced completely, although still functioning. The production date can be derived from the production lot on the item. Example: A10 FD7-411. The first letter refers to the month of manufacture (A=January, B=February, etc.). The second and third letters refer to the year (10=2010, 11=2011, etc.)

Features

The contact blocks developed by the company Pizzato Elettrica contain the experience gained in 30 years of technological development and in millions of pieces sold. The contact blocks range available shown in this chapter is one of the widest in the world in the sector of position switches.

This chapter introduces to some features of Pizzato Elettrica contact blocks, in order to give the final user a better understanding of the technologies behind that element simply named "contact".

We underline that contact blocks are not available for sale (to the public) separately from switches, both because some of them are mechanically connected to the switch and because some technical features may change in accordance with the switch and its function. The following data intend to be a selection of all contact blocks, but cannot be used to determine complete characteristics of the switch equipped with that contact block. For example, when a contact block with positive opening is used in a switch with a not rigid actuator, the result is a switch that on the whole is not one with positive opening.

The complete list of contact blocks currently in production is visible on page 315.

On page 253, the features of the electronic contact block E1, which can be used on position switches for a series of surveys, otherwise complex even with electronic sensors, are explained in detail. On the market doesn't exist an electronic sensor that at the same time has the characteristics of operation precision and repeatability, ability of the switching point adjustment, working temperature and price of this unit.

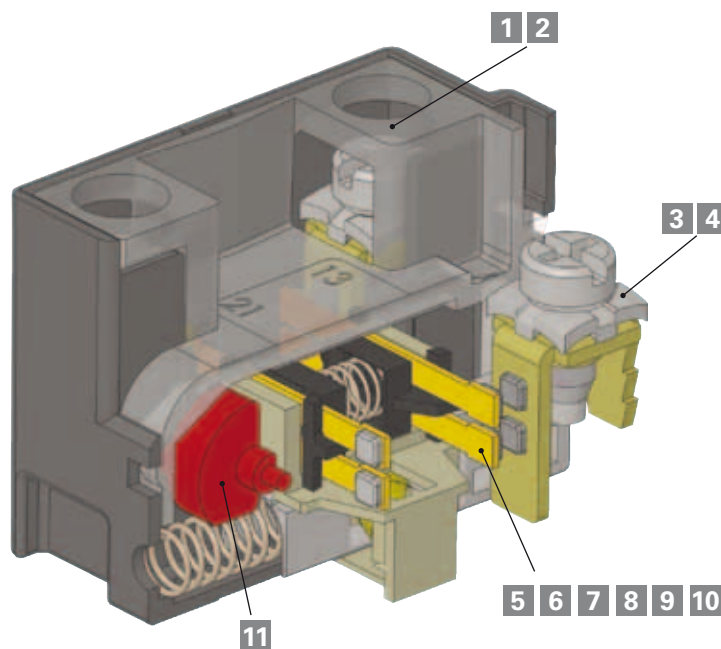

Description	Page	Description	Page
1 Captive screws	310	8 Contact design classification acc. to EN 60947-5-1 X, Y, C, Za, Zb	313
2 Finger protection terminals	310	9 Contact type: Slow action / snap action / snap action with constant pressure	314
3 Clamping screw plates for different diameter cables	310	10 Force on contacts	314
4 Self-lifting clamping screw plates	310	11 Positive opening of contacts	343
5 Contact material: Silver alloy or gold-plated silver alloy	310		
6 Contact technology and reliability: Single bridge, double bridge	311		
7 Operating voltages and currents for reliable switching	312		

1 Captive screws

Switches with this characteristic have clamping screws that remain in seat even if completely unscrewed. This feature reduces wiring time, since the operator does not have to be careful not to unscrew the screws completely and does not risk to lose them by mistake, which is very useful in case of wirings in uncomfortable position.

2 Finger protection

All terminals in the contact blocks have a protection degree IP20, in accordance with the standard EN 60529, therefore they are protected against access to dangerous parts with diameter over 12 mm.



3 Clamping screw plates for different diameter cables

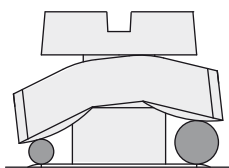

These clamping screw plates have a particular "roofing tile" structure and are connected loosely to the clamping screw. In this way, during the wires fixing, the clamping screw plate is able to suit to cables of different diameter (see picture) and tends to tighten the wires toward the screw instead of permitting them to escape towards the outside.

4 Self-lifting clamping screw plates

Switches with this feature have clamping screw plates that go up or down turning the clamping screw, permitting an easy and quick wiring.

5 Contact material: gold-plated silver alloy

The contact blocks can be supplied with silver electric contacts with a special gold-plated surface, with total gold thickness of one micron. This type of treatment can be useful in environments which are aggressive against silver (very humid or sulphurous atmospheres) and in case of very small electric charges, usually with low voltages and supply currents. The gold thickness used has been studied for resistance to millions of mechanical cycles.

6 Contact technology and reliability

Sometimes, hardly ever, an electric contact may not work. A commutation failure is a typical consequence of an occasional presence of a high resistance on the contacts due to dust, a slight layer of oxidation, or impurity of any kind that remains inside the switch during its wiring. The repeatability of this type of phenomena depends not only on the switch, but also on the environmental working conditions and the type of load the switch drives. These effects are more evident with low electrical loads, when the electric voltage does not succeed in perforating thin layers of oxide or small dust grains.

This type of malfunction may be accepted in the hand-operated devices, because it is enough to repeat the operation in order to make everything work again. This is not the case with position switches, where a failure in a switch could cause considerable damage to the machinery.

In the following table we refer to two typical contact structures (type A and B) normally used in the industry and the ones which have been used by Pizzato Elettrica for several years in most of the switches: movable contacts with double interruption and twin bridge (type C).

As you can see from the table below, this last structure (type C) features the same contact resistance (R) of the simple mobile contact (type A), but with a much lower probability of failure (fe).

In fact, defined x the probability of a single interruption failure, it results that in the contact type A the commutation failure probability $fe=x$, in the type B $fe \cong 2x^2$, whereas in the type C it is $fe = 4x^2$.

This means that if in a certain situation the probability of a single interruption failure x is equal, for instance, to 1×10^{-4} (1 failed interruption every 10.000) we will have:

- for type A one failed commutation every 10,000.
- for type B one failed commutation every 5,000.
- for type C one failed commutation every 25,000,000.

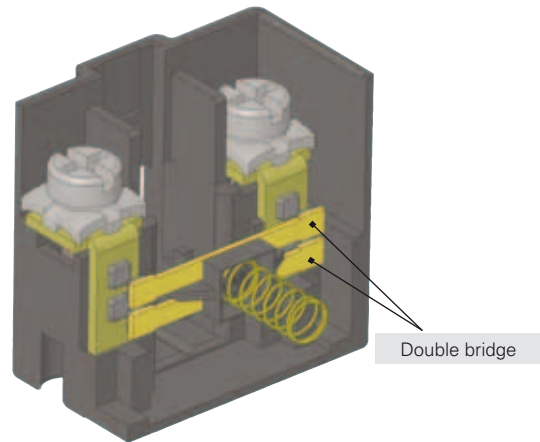

Type	Diagram	Description	Contact resistance R	Failure probability fe
A		simple mobile contact	$R=R_c$	$fe=x$
B		mobile contact, double interruption	$R=2 \cdot R_c$	$fe=2x^2$
C		mobile contact, double interruption, twin bridge	$R= \frac{2 \cdot R_c}{2} = R_c$	$fe=4x^2-4x^3+x^4$

7 Minimum operating voltages and currents for reliable switching

The electric contact reliability depends on a lot of elements that change their effect in accordance with the load type. For high power loads it is essential that the contact should be able to eliminate the heat created during switching. For low power loads, instead, it is important that oxides or other impurities do not obstruct the passing of the electric signal. The choice of the electric contacts material is a compromise between different and sometimes opposing requirements. For position switches contacts a silver alloy is usually used that has proved suited to switching of loads in the range of approximately 1 kW to 0.1 W. Moving below this power range, effects may occur due to the oxide which is created naturally when silver makes contact with the air; just as possible contaminations or impurities in the contact switching chamber, for example the talc powder in the cable sheaths that an installer could accidentally insert in the switch may have a similar effect.

It is not possible to define a fix threshold beyond which the "missing switching phenomenon" does not appear, because there are a lot of mechanical and electric parameters that influence this value. For example, a good twin bridge electric contact in laboratory is able to switch without signal loss loads in the μW range for dozens of millions of handling operations. However, this does not mean that the same contact is able to provide the same services when the switch operates in an area with sudden changes of temperature (condensate formation) or with few switchings (oxides formation).

To avoid part of this type of problems, for very low loads are used gold plated contacts, profiting from the non-oxidability of this material. The thickness of the gold-plating should be adequate to be mechanically resistant to switching and to be electrically resistant to possible sparks that may vaporize it. It is for this reason that Pizzato Elettrica uses micron thickness gold plating suitable for millions of working cycles. Gold platings with lower thickness have simply an aesthetic function, suitable only for protection of the product against oxidation when kept in stock for long time.

The minimum current and voltage values suggested by Pizzato Elettrica are readable on the diagram below, divided in two areas defined by a steady power limit. These values identify voltage and current combinations with high commutation reliability in most industrial fields. The lower voltage and current limits shown in the diagram are typical minimum values in industrial application that may also be reduced in not general conditions. It is recommended, however, to always evaluate that the power signal to commutate should be at least one magnitude order higher than the noise produced in the electric circuit, in particular when circuit cables are long and pass through areas with high electromagnetic fields, especially with signal powers lower than 10 mW.

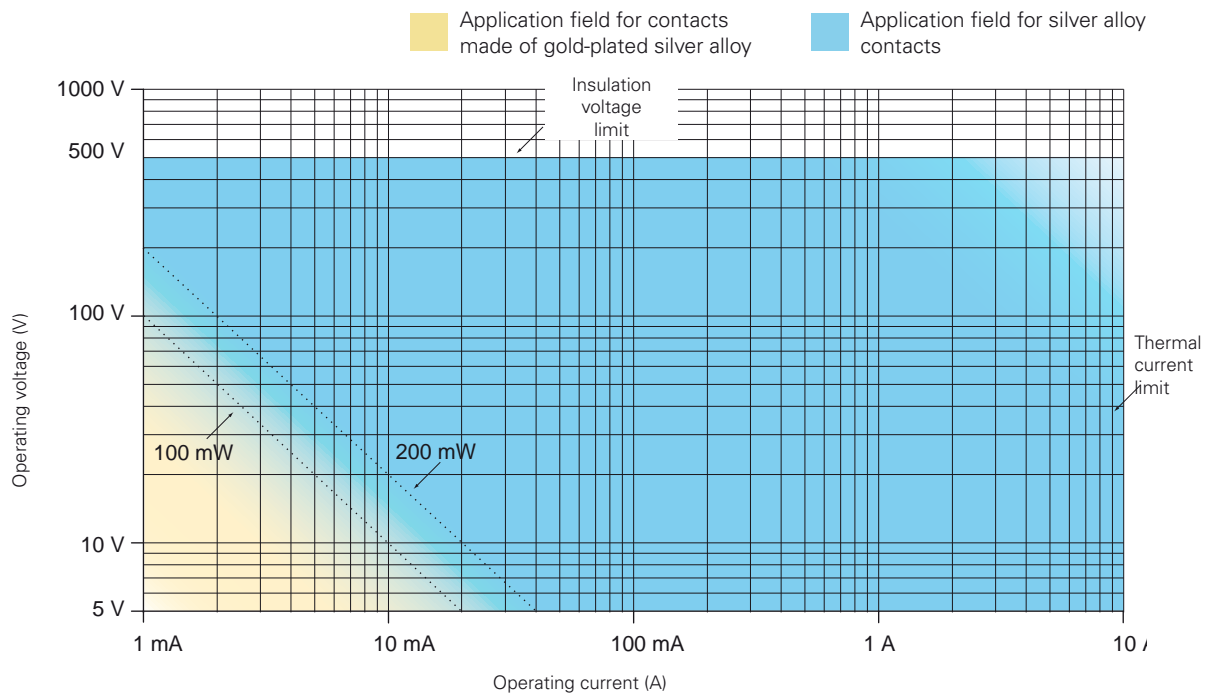

100 mW Suggested limit for general applications with snap action contact blocks with silver alloy contacts.

200 mW Suggested limit for general applications with snap action contact blocks with silver alloy contacts.

8 Classification of the contact block acc. to the EN 60947-5-1

Design	Figure	Symbol	Description
X			Double interruption contact element with two terminals
Y			
C			Change-over contact element with single interruption and three terminals
Za			Change-over contact element with double interruption and four terminals. The contacts have identical polarity
Zb			Change-over contact element with double interruption and four terminals. Mobile contacts are electrically separated

Electrically separated contacts

Symbol "+" between contact designs (e.g. X+X, Za+Za, X+X+Y, etc.) indicates the combinations of simple contact blocks **electrically separated** between each other.

The **electrically separated contacts allow** the application of different voltages on the contacts and the connection of loads on different polarities (figure 1).

Prescriptions and restrictions for Za contacts

Electrical loads must be connected to the same phase or polarity. The contacts **are not** electrically separated, connection of different voltages between the NC contact and the NO contact is not allowed (fig. 2 and 3).

Also, as prescribed by the standard EN 60947-5-1 paragraph K.7.1.4.6.1, if Za contacts with positive opening for safety applications are used, the following restrictions have to be adopted:

" If the control accessory has shifting contacts components with design C or Za, **you have to use only one contact component** (closure or cutoff). In case of shifting contact with design Zb, both contacts may be used..."

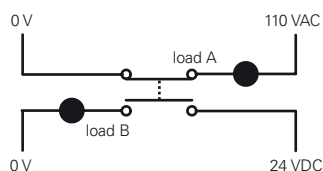
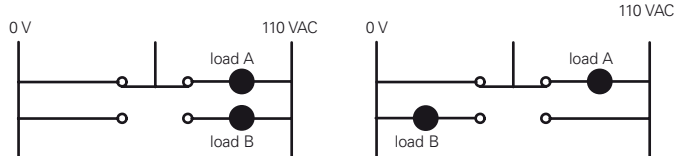
Zb design contactfigure 1: **correct****Za design contact**figure 2: **correct**figure 3: **incorrect**

9 Contact block with dependent action: slow action and snap action

Contact blocks with slow action: component where the speed of the contact movement ($V1$) depends on the speed of the switch actuation (V). The contact armature advances at a rate proportional to the actuation speed.

The slow action contact block is suitable for applications having low to medium currents and quick actuation movements. It has no differential travel.

$$V = V1$$

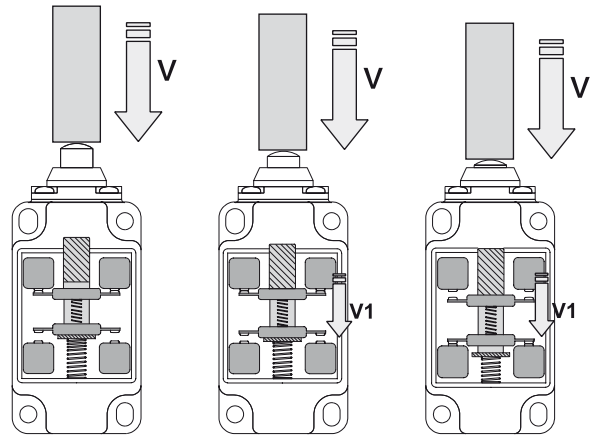

Contact block with snap action: component where the speed of the contact movement ($V1$) doesn't depend on the speed of the switch actuation (V). After reaching a predetermined point in travel, the contact armature snaps causing the contacts switching.

The snap action contact block is suitable for applications having high currents and/or slow actuation movements. This kind of contact block has a differential travel.

$$V \neq V1$$

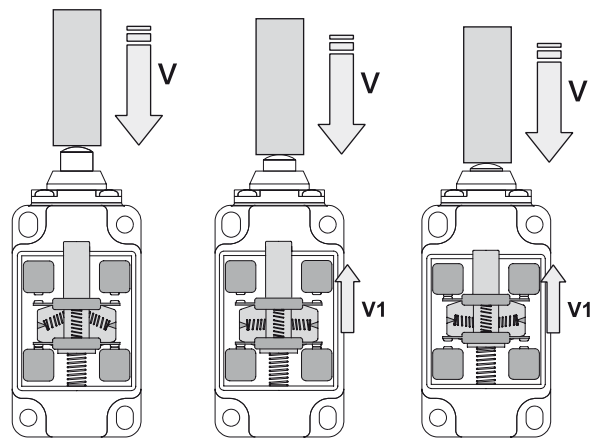

10 Contact block: diagrams of the force on the contacts

The following diagrams show the relationship between of the force exerted on the contacts (F) compared to the switch armature travel.

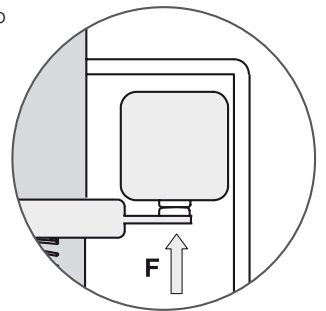
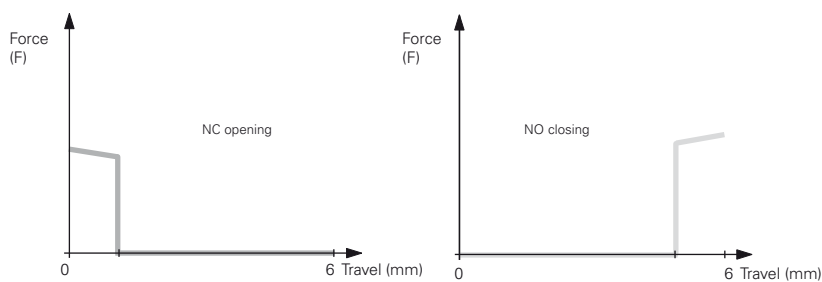

Contact blocks with slow action

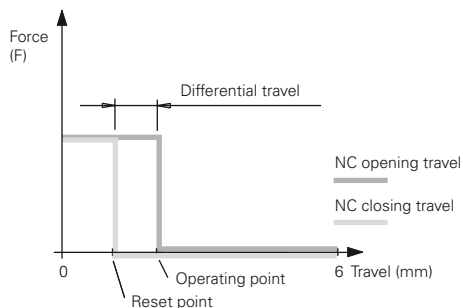

Contact blocks with snap action and constant pressure 5, 11, 12. The pressure on the contact remains constant while approaching to the snap point.

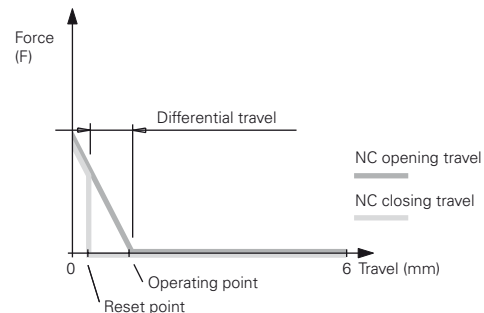

Contact blocks with snap action 2, 3, 17. The pressure on the contact decreases while approaching to the snap point.

Contact blocks FD-FP-FL-FC-FR-FM-FX-FZ-FK-FW-FS series

Contact blocks	Contact diagram	Linear travel diagram	Contact design	Operation type	Positive opening \ominus	Contact type	Captive screws	Terminals with finger protection	Gold-plated contacts	
2	2x(1NO-1NC)			Za+Za	snap action	no	Double interruption	no	no	Not Available
3	1NO-1NC			Za	snap action	no	Double interruption	no	no	Not Available
5	1NO+1NC			Zb	snap action	yes	Double interruption, twin bridge	yes	yes	Available
6	1NO+1NC			Zb	slow action	yes	Double interruption, twin bridge	yes	yes	Available
7	1NO+1NC			Zb	slow action	yes	Double interruption, twin bridge	yes	yes	Available
8	1NC			Y	slow action	yes	Double interruption, twin bridge	yes	yes	Available
9	2NC			Y+Y	slow action	yes	Double interruption, twin bridge	yes	yes	Available
10	2NO			X+X	slow action	no	Double interruption, twin bridge	yes	yes	Available
11	2NC			Y+Y	snap action	yes	Double interruption, twin bridge	yes	yes	Available
12	2NO			X+X	snap action	no	Double interruption, twin bridge	yes	yes	Available
13	2NC			Y+Y	slow action	yes	Double interruption, twin bridge	yes	yes	Available
14	2NC			Y+Y	slow action	yes	Double interruption, twin bridge	yes	yes	Available
15	2NO			X+X	slow action	no	Double interruption, twin bridge	yes	yes	Available
16	2NC			Y+Y	slow action	yes	Double interruption, twin bridge	yes	yes	Available
18	1NO+1NC			Zb	slow action	yes	Double interruption, twin bridge	yes	yes	Available
20	1NO+2NC			Y+Y+X	slow action	yes	Double interruption, twin bridge	yes	yes	Available
21	3NC			Y+Y+Y	slow action	yes	Double interruption, twin bridge	yes	yes	Available
22	2NO+1NC			Y+X+X	slow action	yes	Double interruption, twin bridge	yes	yes	Available
28	1NO+2NC			Y+Y+X	slow action	yes	Double interruption, twin bridge	yes	yes	Available
29	3NC			Y+Y+Y	slow action	yes	Double interruption, twin bridge	yes	yes	Available
30	3NC			Y+Y+Y	slow action	yes	Double interruption, twin bridge	yes	yes	Available
33	1NO+1NC			Zb	slow action	yes	Double interruption, twin bridge	yes	yes	Available
34	2NC			Y+Y	slow action	yes	Double interruption, twin bridge	yes	yes	Available
37	1NO+1NC			Zb	slow action	yes	Double interruption, twin bridge	yes	yes	Available
66	1NC			Y	slow action	yes	Double interruption, twin bridge	yes	yes	Available
67	1NO			X	slow action	no	Double interruption, twin bridge	yes	yes	Available
E1	1NO-1NC			PNP	electronic	no	electronic	no	no	/

Contact blocks FG series

Contact blocks	Contact diagram	Linear travel diagram	Contact design	Operation type	Positive opening \ominus	Contact type	Captive screws	Terminals with finger protection	Gold-plated contacts
60•	Contact block with 4 poles and multiple contact designs. See page 93			slow action	yes	With double interruption and twin bridge and double support	yes	yes	Available

Contact blocks NA-NB-NF series

Contact blocks	Contact diagram	Linear travel diagram	Contact design	Operation type	Positive opening \ominus	Contact type	Captive screws	Terminals with finger protection	Gold-plated contacts
B11	1NO+1NC		Zb	snap action	yes	Double interruption	/	/	Available
B02	2NC		Y+Y	snap action	yes	Double interruption	/	/	Available
B12	1NO+2NC		X+Y+Y	snap action	yes	Double interruption	/	/	Available
B22	2NO+2NC		X+X+Y+Y	snap action	yes	Double interruption	/	/	Available
G11	1NO+1NC		Zb	slow action	yes	Double interruption	/	/	Available
G02	2NC		Y+Y	slow action	yes	Double interruption	/	/	Available
G12	1NO+2NC		X+Y+Y	slow action	yes	Double interruption	/	/	Available
G22	2NO+2NC		X+X+Y+Y	slow action	yes	Double interruption	/	/	Available
H11	1NO+1NC		Zb	slow action	yes	Double interruption	/	/	Available
H12	1NO+2NC		X+Y+Y	slow action	yes	Double interruption	/	/	Available
H22	2NO+2NC		X+X+Y+Y	slow action	yes	Double interruption	/	/	Available
L11	1NO+1NC		Zb	slow action	yes	Double interruption	/	/	Available
L12	1NO+2NC		X+Y+Y	slow action	yes	Double interruption	/	/	Available
L22	2NO+2NC		X+X+Y+Y	slow action	yes	Double interruption	/	/	Available
BA1	1NO+1NC in deviation		C	snap action	yes	Double interruption	/	/	Available

Contact blocks HP series

Contact blocks	Contact diagram	Linear travel diagram	Contact design	Operation type	Positive opening \ominus	Contact type	Captive screws	Terminals with finger protection	Gold-plated contacts
50C	1NO+1NC		Zb	snap action	yes	Double interruption	/	/	Available
50D	2NC		Y+Y	snap action	yes	Double interruption	/	/	Available
50 F	1NO+2NC		X+Y+Y	snap action	yes	Double interruption	/	/	Available
50M	2NO+2NC		X+X+Y+Y	snap action	yes	Double interruption	/	/	Available
52C	1NO+1NC		Zb	slow action	yes	Double interruption	/	/	Available
52D	2NC		Y+Y	slow action	yes	Double interruption	/	/	Available
52 F	1NO+2NC		X+Y+Y	slow action	yes	Double interruption	/	/	Available
52M	2NO+2NC		X+X+Y+Y	slow action	yes	Double interruption	/	/	Available
53C	1NO+1NC		Zb	slow action	yes	Double interruption	/	/	Available
53 F	1NO+2NC		X+Y+Y	slow action	yes	Double interruption	/	/	Available
53M	2NO+2NC		X+X+Y+Y	slow action	yes	Double interruption	/	/	Available

Connection diagram for assembled connectors

For FD - FL - FM - FZ - FC series with metal housing

Contact block 2 1NO-1NC+1NO-1NC	Contact block 5 1NO+1NC	Contact block 6 1NO+1NC	Contact block 7 1NO+1NC	Contact block 9 2NC	Contact block 10 2NO	Contact block 11 2NC	Contact block 12 2NO	Contact block 13 2NC	
M12 connector, 8 poles	M12 connector, 5 poles	M12 connector, 5 poles	M12 connector, 5 poles	M12 connector, 5 poles	M12 connector, 5 poles	M12 connector, 5 poles	M12 connector, 5 poles	M12 connector, 5 poles	
Contacts	Pin no.	Contacts	Pin no.	Contacts	Pin no.	Contacts	Pin no.	Contacts	Pin no.
NO	3-4	NC	1-2	NC	1-2	NC	1-2	NO	1-2
NC	5-6	NO	3-4	NO	3-4	NO	3-4	NC	3-4
NC	7-8	ground	5	ground	5	ground	5	ground	5
NO	1-2								

Contact block 14 2NC	Contact block 15 2NO	Contact block 16 2NC	Contact block 18 1NO+1NC	Contact block 20 2NC+1NO	Contact block 21 3NC	Contact block 22 1NC+2NO	Contact block 33 1NC+1NO	Contact block 34 2NC	
M12 connector, 5 poles	M12 connector, 5 poles	M12 connector, 5 poles	M12 connector, 5 poles	M12 connector, 8 poles	M12 connector, 8 poles	M12 connector, 8 poles	M12 connector, 5 poles	M12 connector, 5 poles	
Contacts	Pin no.	Contacts	Pin no.	Contacts	Pin no.	Contacts	Pin no.	Contacts	Pin no.
NC (1°)	1-2	NO (1°)	1-2	NC, lever at the right	1-2	NC	3-4	NC	1-2
NC (2°)	3-4	NO (2°)	3-4	NC	3-4	NC	5-6	NO	3-4
ground	5	ground	5	NC, lever to the left	3-4	NO	5-6	NO	3-4
				NO	3-4	NC	7-8	ground	5
				ground	5	NO	7-8	ground	5
				NO	7-8	NC	7-8	ground	5
				ground	1	ground	1	ground	5

Contact block 28 2NC+1NO	Contact block 29 3NC	Contact block 30 3NC			
M12 connector, 8 poles	M12 connector, 8 poles	M12 connector, 8 poles			
Contacts	Pin no.	Contacts	Pin no.	Contacts	Pin no.
NC	3-4	NC	3-4	NC	3-4
NC	5-6	NC	5-6	NC	5-6
NO	7-8	NC	7-8	NC	7-8
ground	1	ground	1	ground	1

Contact block E1 PNP	
M12 connector, 5 poles	
Contacts	Pin no.
+	1
-	3
NC	2
NO	4
ground	5

For FS series with technopolymer housing

Contact block 18 1NO+1NC	Contact block 20 2NC+1NO	Contact block 21 3NC	Contact block 28 2NC+1NO	Contact block 29 3NC	Contact block 30 3NC
M12 connector, 8 poles	M12 connector, 8 poles	M12 connector, 8 poles	M12 connector, 8 poles	M12 connector, 8 poles	M12 connector, 8 poles
Contacts	Pin no.	Contacts	Pin no.	Contacts	Pin no.
A1-A2	1-2	A1-A2	1-2	A1-A2	1-2
NC	3-4	NC	3-4	NC	3-4
NO	5-6	NC	5-6	NC	5-6
		NO	7-8	NC	7-8
		NC	7-8	NC	7-8

Connection diagram for assembled connectors

For FP - FR - FX - FW series with technopolymer housing

Contact block 2 1NO-1NC+1NO-1NC	Contact block 5 1NO+1NC	Contact block 6 1NO+1NC	Contact block 7 1NO+1NC	Contact block 9 2NC	Contact block 10 2NO	Contact block 11 2NC	Contact block 12 2NO	Contact block 13 2NC	
M12 connector, 8 poles	M12 connector, 4 poles	M12 connector, 4 poles	M12 connector, 4 poles	M12 connector, 4 poles	M12 connector, 4 poles	M12 connector, 4 poles	M12 connector, 4 poles	M12 connector, 4 poles	
Contacts	Pin no.	Contacts	Pin no.	Contacts	Pin no.	Contacts	Pin no.	Contacts	Pin no.
NO	3-4	NC	1-2	NC	1-2	NC	1-2	NO	1-2
NC	5-6	NO	3-4	NO	3-4	NO	3-4	NC	3-4
NC	7-8								
NO	1-2								

Contact block 14 2NC	Contact block 15 2NO	Contact block 16 2NC	Contact block 18 1NO+1NC	Contact block 20 2NC+1NO	Contact block 21 3NC	Contact block 22 1NC+2NO	Contact block 33 1NC+1NO	Contact block 34 2NC	
M12 connector, 4 poles	M12 connector, 4 poles	M12 connector, 4 poles	M12 connector, 4 poles	M12 connector, 8 poles	M12 connector, 8 poles	M12 connector, 8 poles	M12 connector, 4 poles	M12 connector, 4 poles	
Contacts	Pin no.	Contacts	Pin no.	Contacts	Pin no.	Contacts	Pin no.	Contacts	Pin no.
NC (1°)	1-2	NO (1°)	1-2	NC, lever at the right	1-2	NC	3-4	NC	1-2
NC (2°)	3-4	NO (2°)	3-4	NC, lever to the left	3-4	NO	5-6	NO	3-4
						NC	7-8		
						NO	7-8		

Contact block 28 2NC+1NO	Contact block 29 3NC	Contact block 30 3NC	Contact block E1 PNP		
M12 connector, 8 poles	M12 connector, 8 poles	M12 connector, 8 poles	M12 connector, 4 poles		
Contacts	Pin no.	Contacts	Pin no.	Contacts	Pin no.
NC	3-4	NC	3-4	+	1
NC	5-6	NC	5-6	-	3
NO	7-8	NC	7-8	NC	2
				NO	4

For FG series with metal housing and M23 connector

Contact block 60A 2NO+2NC	Contact block 60B 1NO+3NC	Contact block 60C 4NC	Contact block 60D 1NO+3NC	Contact block 60E 1NO+3NC	Contact block 60F 2NO+2NC	Contact block 60G 4NC	Contact block 60H 4NC	Contact block 60I 1NO+3NC	Contact block 60L 2NO+2NC
M23 connector 12 poles	M23 connector 12 poles	M23 connector 12 poles	M23 connector 12 poles	M23 connector 12 poles	M23 connector 12 poles	M23 connector 12 poles	M23 connector 12 poles	M23 connector 12 poles	M23 connector 12 poles
Contacts Pin no.	Contacts Pin no.	Contacts Pin no.	Contacts Pin no.	Contacts Pin no.	Contacts Pin no.	Contacts Pin no.	Contacts Pin no.	Contacts Pin no.	Contacts Pin no.
A1-A2 1-2	A1-A2 1-2	A1-A2 1-2	A1-A2 1-2	A1-A2 1-2	A1-A2 1-2	A1-A2 1-2	A1-A2 1-2	A1-A2 1-2	A1-A2 1-2
NC 3-4	NC 3-4	NC 3-4	NO 3-4	NC 3-4	NC 3-4	NC 3-4	NC 3-4	NC 3-4	NC 3-4
NC 5-6	NC 5-6	NC 5-6	NC 5-6	NC 5-6	NC 5-6	NC 5-6	NC 5-6	NC 5-6	NC 5-6
NO 7-8	NC 7-8	NC 7-8	NC 7-8	NC 7-8	NO 7-8	NC 7-8	NC 7-8	NC 7-8	NO 7-8
NO 9-10	NO 9-10	NC 9-10	NC 9-10	NO 9-10	NO 9-10	NC 9-10	NC 9-10	NO 9-10	NO 9-10
ground 11	ground 11	ground 11	ground 11	ground 11	ground 11	ground 11	ground 11	ground 11	ground 11

Contact block 60M 3NO+1NC	Contact block 60N 3NO+1NC	Contact block 60P 4NC	Contact block 60R 2NO+2NC	Contact block 60S 2NO+2NC	Contact block 60T 1NO+3NC	Contact block 60U 4NC	Contact block 60V 2NO+2NC	Contact block 60X 1NO+3NC	Contact block 60Y 2NO+2NC
M23 connector 12 poles	M23 connector 12 poles	M23 connector 12 poles	M23 connector 12 poles	M23 connector 12 poles	M23 connector 12 poles	M23 connector 12 poles	M23 connector 12 poles	M23 connector 12 poles	M23 connector 12 poles
Contacts Pin no.	Contacts Pin no.	Contacts Pin no.	Contacts Pin no.	Contacts Pin no.	Contacts Pin no.	Contacts Pin no.	Contacts Pin no.	Contacts Pin no.	Contacts Pin no.
A1-A2 1-2	A1-A2 1-2	A1-A2 1-2	A1-A2 1-2	A1-A2 1-2	A1-A2 1-2	A1-A2 1-2	A1-A2 1-2	A1-A2 1-2	A1-A2 1-2
NO 3-4	NO 3-4	NC 3-4	NC 3-4	NC 3-4	NC 3-4	NC 3-4	NC 3-4	NO 3-4	NC 3-4
NC 5-6	NC 5-6	NC 5-6	NC 5-6	NC 5-6	NC 5-6	NC 5-6	NC 5-6	NC 5-6	NC 5-6
NO 7-8	NO 7-8	NC 7-8	NC 7-8	NO 7-8	NC 7-8	NC 7-8	NO 7-8	NC 7-8	NC 7-8
NO 9-10	NO 9-10	NC 9-10	NO 9-10	NO 9-10	NO 9-10	NC 9-10	NO 9-10	NC 9-10	NO 9-10
ground 11	ground 11	ground 11	ground 11	ground 11	ground 11	ground 11	ground 11	ground 11	ground 11

Contact block 61A 1NO+3NC	Contact block 61B 2NO+2NC	Contact block 61C 3NO+1NC	Contact block 61D 3NO+1NC	Contact block 61E 3NO+1NC	Contact block 61G 3NO+1NC	Contact block 61H 2NO+2NC	Contact block 61M 3NO+1NC	Contact block 61R 1NO+3NC	Contact block 61S 3NO+1NC
M23 connector 12 poles	M23 connector 12 poles	M23 connector 12 poles	M23 connector 12 poles	M23 connector 12 poles	M23 connector 12 poles	M23 connector 12 poles	M23 connector 12 poles	M23 connector 12 poles	M23 connector 12 poles
Contacts Pin no.	Contacts Pin no.	Contacts Pin no.	Contacts Pin no.	Contacts Pin no.	Contacts Pin no.	Contacts Pin no.	Contacts Pin no.	Contacts Pin no.	Contacts Pin no.
A1-A2 1-2	A1-A2 1-2	A1-A2 1-2	A1-A2 1-2	A1-A2 1-2	A1-A2 1-2	A1-A2 1-2	A1-A2 1-2	A1-A2 1-2	A1-A2 1-2
NC 3-4	NC 3-4	NO 3-4	NO 3-4	NO 3-4	NO 3-4	NC 3-4	NC 3-4	NC 3-4	NO 3-4
NC 5-6	NC 5-6	NC 5-6	NC 5-6	NC 5-6	NC 5-6	NC 5-6	NC 5-6	NC 5-6	NC 5-6
NC 7-8	NO 7-8	NO 7-8	NO 7-8	NO 7-8	NO 7-8	NO 7-8	NO 7-8	NC 7-8	NO 7-8
NO 9-10	NO 9-10	NO 9-10	NO 9-10	NO 9-10	NO 9-10	NO 9-10	NO 9-10	NO 9-10	NO 9-10
ground 11	ground 11	ground 11	ground 11	ground 11	ground 11	ground 11	ground 11	ground 11	ground 11

For FG series with metal housing and M12 connector

Contact block 60A 2NO+2NC	Contact block 60B 1NO+3NC	Contact block 60C 4NC	Contact block 60D 1NO+3NC	Contact block 60E 1NO+3NC	Contact block 60F 2NO+2NC	Contact block 60G 4NC	Contact block 60H 4NC	Contact block 60I 1NO+3NC	Contact block 60L 2NO+2NC
M12 connector 12 poles	M12 connector 12 poles	M12 connector 12 poles	M12 connector 12 poles	M12 connector 12 poles	M12 connector 12 poles	M12 connector 12 poles	M12 connector 12 poles	M12 connector 12 poles	M12 connector 12 poles
Contacts Pin no.	Contacts Pin no.	Contacts Pin no.	Contacts Pin no.	Contacts Pin no.	Contacts Pin no.	Contacts Pin no.	Contacts Pin no.	Contacts Pin no.	Contacts Pin no.
A1-A2 1-2	A1-A2 1-2	A1-A2 1-2	A1-A2 1-2	A1-A2 1-2	A1-A2 1-2	A1-A2 1-2	A1-A2 1-2	A1-A2 1-2	A1-A2 1-2
NC	NC	NC	NO	NC	NC	NC	NC	NC	NC
NC	NC	NC	NC	NC	NC	NC	NC	NC	NC
NO	NC	NC	NC	NO	NO	NC	NC	NC	NO
NO	NO	NC	NC	NO	NC	NC	NC	NO	NO

Contact block 60M 3NO+1NC	Contact block 60N 3NO+1NC	Contact block 60P 4NC	Contact block 60R 2NO+2NC	Contact block 60S 2NO+2NC	Contact block 60T 1NO+3NC	Contact block 60U 4NC	Contact block 60V 2NO+2NC	Contact block 60X 1NO+3NC	Contact block 60Y 2NO+2NC
M12 connector 12 poles	M12 connector 12 poles	M12 connector 12 poles	M12 connector 12 poles	M12 connector 12 poles	M12 connector 12 poles	M12 connector 12 poles	M12 connector 12 poles	M12 connector 12 poles	M12 connector 12 poles
Contacts Pin no.	Contacts Pin no.	Contacts Pin no.	Contacts Pin no.	Contacts Pin no.	Contacts Pin no.	Contacts Pin no.	Contacts Pin no.	Contacts Pin no.	Contacts Pin no.
A1-A2 1-2	A1-A2 1-2	A1-A2 1-2	A1-A2 1-2	A1-A2 1-2	A1-A2 1-2	A1-A2 1-2	A1-A2 1-2	A1-A2 1-2	A1-A2 1-2
NO	NO	NC	NC	NC	NC	NC	NC	NO	NC
NC	NC	NC	NC	NC	NC	NC	NC	NC	NC
NO	NO	NC	NO	NO	NC	NC	NO	NC	NO
NO	NO	NC	NO	NO	NC	NC	NO	NC	NO

Contact block 61A 1NO+3NC	Contact block 61B 2NO+2NC	Contact block 61C 3NO+1NC	Contact block 61D 3NO+1NC	Contact block 61E 3NO+1NC	Contact block 61G 3NO+1NC	Contact block 61H 2NO+2NC	Contact block 61M 3NO+1NC	Contact block 61R 1NO+3NC	Contact block 61S 3NO+1NC
M12 connector 12 poles	M12 connector 12 poles	M12 connector 12 poles	M12 connector 12 poles	M12 connector 12 poles	M12 connector 12 poles	M12 connector 12 poles	M12 connector 12 poles	M12 connector 12 poles	M12 connector 12 poles
Contacts Pin no.	Contacts Pin no.	Contacts Pin no.	Contacts Pin no.	Contacts Pin no.	Contacts Pin no.	Contacts Pin no.	Contacts Pin no.	Contacts Pin no.	Contacts Pin no.
A1-A2 1-2	A1-A2 1-2	A1-A2 1-2	A1-A2 1-2	A1-A2 1-2	A1-A2 1-2	A1-A2 1-2	A1-A2 1-2	A1-A2 1-2	A1-A2 1-2
NC	NC	NO	NO	NO	NO	NC	NC	NO	NO
NC	NC	NC	NC	NC	NC	NC	NC	NC	NC
NC	NO	NO	NO	NO	NO	NO	NO	NC	NO
NO	NO	NO	NO	NO	NO	NO	NO	NO	NO

Note: the wires connected to pins 11 and 12 of the M12 connector can be used to activate the LEDs in FG series configurations with freely connectable LEDs.

Outline dimension with assembled connectors

Switch with M12 connector mounted below

Switch with M12 connector, mounted at the right, at the left, or below

Switch with M23 connector mounted below

Switch with M23 connector, mounted at the right or left

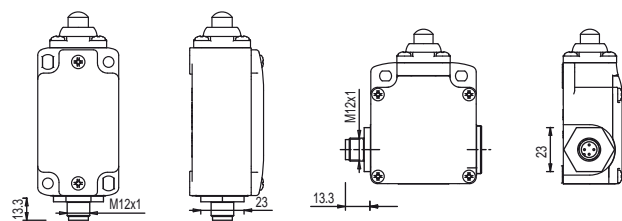

FD - FP - FL - FC - FR - FM - FX - FZ - FW - FS - FG - NG series

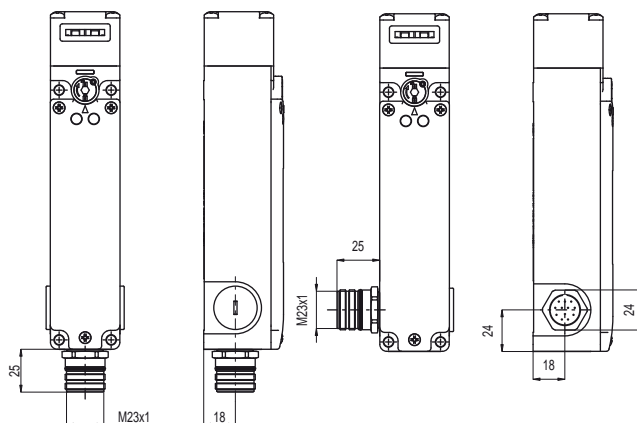

FG - NG series

Minimum distances required for insertion of the connectors

Switch with M12 connector mounted below

Switch with M12 connector, mounted at the right or left

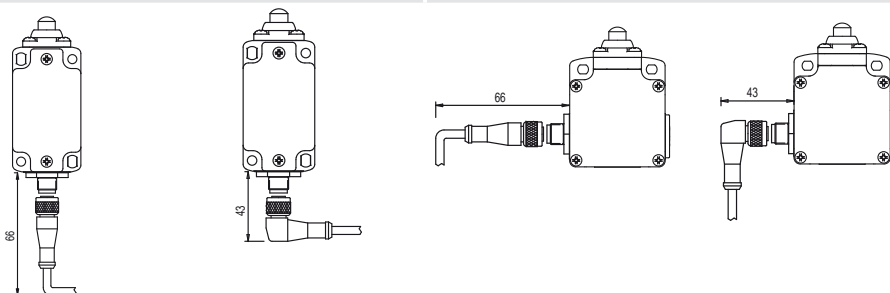

FD - FP - FL - FC - FR - FM - FX - FZ - FW - FS - FG - NG series

Switch with M12 connector, at bottom

Switch with M12 connector, at the right

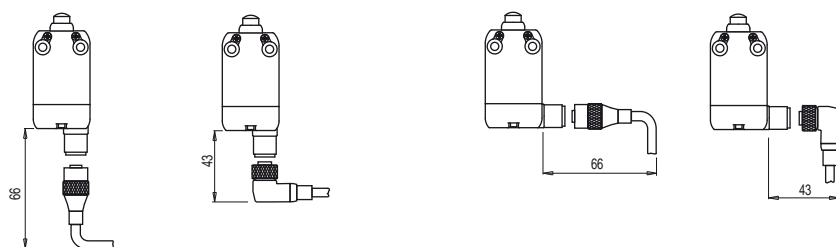

NA - NB - NF series

Sensor with M8 connector

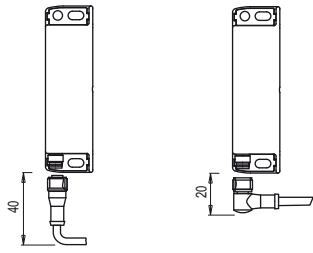

Sensor with M12 connector

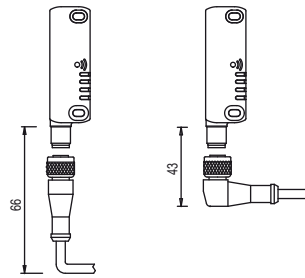

SR series

ST series

Hinge with M12 connector

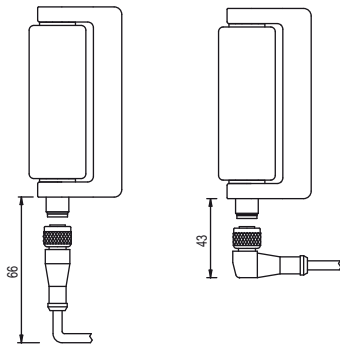

HP - HX series

Switch with M23 connector mounted below

Switch with M23 connector, mounted at the right or left

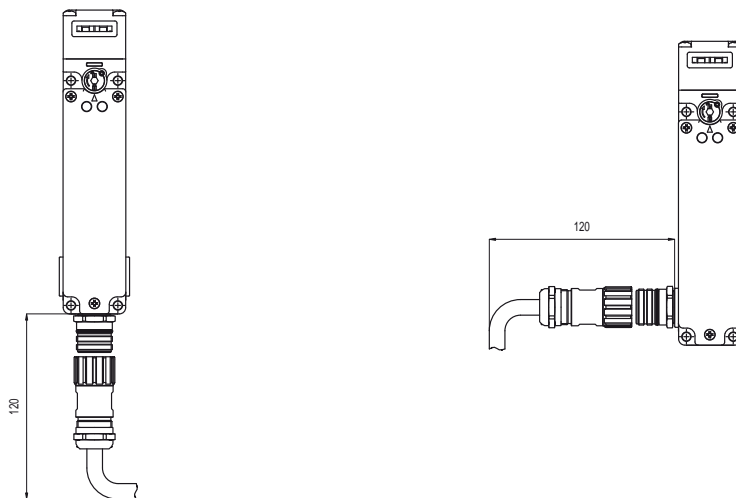

FG - NG series

Definitions complying with the standards EN 60947-1 and EN 60947-5-1

Control switches

A mechanical switching device which serves the purpose of controlling the operations of switch gear or control-gear, including signalling, electrical interlocking, etc.

Utilization category

A combination of specified requirements related to the conditions in which the switching device fulfils its purpose.

Operating cycle

Succession of two movements, one for closure and second for opening.

Rated current I_e

A current that takes into account the rated operating voltage, the rated frequency, the utilization category and the type of protective enclosure, if appropriate.

Thermal current I_{th}

Max. value of current to be used for temperature-rise tests of equipment without enclosure, in free air. Its value shall be least equal to the maximum value of the rated operational current I_e of the equipment without enclosure, in eight-hour duty.

Electrical endurance

Number of on-load operating cycles, under the conditions defined by the corresponding product standard, which can be made without repair or replacement.

Mechanical endurance

Number of no-load operating cycles (i.e. without current at the main contacts), under the conditions defined by the corresponding product standard, which can be effected before it becomes necessary to service or replace any mechanical parts.

Contact element

The parts, fixed or movable, conducting or insulating, of a control switch necessary to close and open one single conducting path of a circuit.

Single interruption contact element

Contact element which opens or closes the conducting path of its circuit in one location only.

Double interruption contact element

Contact element which opens or closes the conducting path of its circuit in two locations in series.

Make-contact element (normally open)

Contact element which closes a conducting path when the control switch is actuated.

Break-contact element (normally closed)

Contact element which opens a conducting path when the control switch is actuated.

Change-over contact elements

Contact element combination which includes one make-contact element and one break-contact element.

Electrically separated contact elements

Contact elements belonging to the same control switch, but adequately insulated from each other, so they can be connected to electric circuits with different tension.

Independent action contact element (snap action)

Contact element of a manual or automatic control device in which the velocity of contact motion is substantially independent of the actuator's motion velocity.

Dependent action contact element (slow action)

Contact element of a manual or automatic control device, the contact motion velocity of which depends on the actuator's motion velocity.

Minimum actuating force

The minimum force value to be applied to the actuator that will cause all contacts to reach their switched position.

Position switch

Pilot switch the actuating system of which is operated by a moving part of the machine, when that part reaches a predetermined position.

Foot switch

Control switch having an actuator intended to be operated by the force exerted by a foot.

Pre-travel of the actuator

The maximum travel of the actuator which does not cause any travel of the contact elements.

Ambient temperature

The air temperature determined under prescribed conditions surrounding the complete switching device.

Rated operating voltage U_e

Voltage which, combined with the rated operational current I_e , determinates the application of the equipment and the referred utilization categories.

Rated insulation voltage U_i

Voltage to which dielectric test voltage and creepage distances are referred.

Impulse withstand voltage U_{imp}

The highest peak value of an impulse voltage, of a prescribed shape and polarity, which does not cause destructive discharge under the specified test conditions.

Contact blocks

Contact element or contact elements combination which can be combined with similar units, operated by a common actuating system

Markings and quality marks

CE marking

 The CE marking is a mandatory declaration made by the manufacturer of a product in order to indicate that the product satisfies all requirements foreseen by the directives (regulated by the European Community) on subjects of safety and quality. Its function therefore is to guarantee to the governing authorities of the various countries the fulfilment of their obligations under the law.

IMQ marking



The IMQ (Italian Institute of the Quality Mark) is the organization in Italy (third and independent) whose task is to check and certify the compliance of the materials and the equipment with the safety standards (CEI standards in the electric and electronic branch). This voluntary conformity certification is a guarantee of quality, safety and technical value.

UL marking



UL (Underwriters Laboratories Inc.) is an independent non-profit laboratory that tests materials, devices, products, equipment, constructions, methods and systems with regard to their risk for human life and goods according to the standard in force in the United States and Canada. Regulations and testing made by UL is often taken as valid, by many governing authorities, with regard to conformity with local regulations on the subject of safety.

CCC marking



The CQC is the organization in the Chinese Popular Republic whose task is to check and certify the low voltage electrical material.

This organization issues the product mark CCC which certifies the passing of electrical/mechanical conformity tests by products and the compliance of the company quality system with required standards. To obtain the mark, the Chinese organization makes preliminary company visits and periodical verification inspections. Position switches cannot be sold in the Chinese territory without this mark.

TÜV SÜD certification mark



TÜV SÜD is an international authority claiming long-standing experience in the certification of operating safety for electrical, electromechanical and electronic products. In the course of type approval, TÜV SÜD closely inspects the quality throughout all the stages concerning product development, from software design and completion, to production and to the tests conducted according to ISO/IEC standards. The operating safety certification is obtained voluntarily and has a high technical value, since it not only certifies the electrical safety of the product, but also its specific operating suitability for use in safety applications according to the IEC 61508 standard.

EAC marking



The EAC certificate of conformity is a certificate issued by a Customs Union certification body formed by Russia, Belarus and Kazakhstan, with which the conformity of a product is certified with the essential safety requirements laid down by one or more Technical Regulations (Directives) of the Customs Union.

International and European Standards

EN 50041: Low voltage switchgear and controlgear for industrial use. Control switches. Position switches 42.5x80 mm. Dimensions and features

EN 50047: Low voltage switchgear and controlgear for industrial use. Control switches. Position switches 30x55 mm. Dimensions and features

EN ISO 14119: Safety of machinery. Interlocking devices associated with guards. Design and selection principles.

EN ISO 12100: Safety of machinery. General design principles. Risk assessment and risk reduction.

EN ISO 13849-1: Safety of machinery. Safety-related parts of control systems. Part 1: General principles for design.

EN ISO 13850: Safety of machinery. Devices for emergency stop, functional aspects. Design principles.

EN 61000-6-3 (equivalent to IEC 61000-6-3): Electromagnetic compatibility. Generic emission standard. Part 1: residential, commercial and light-industrial environments.

EN 61000-6-2 (equivalent to IEC 61000-6-2): Electromagnetic compatibility. Generic immunity standard. Part 2: Industrial environments.

EN ISO 13855: Safety of machinery. Positioning of safeguards with respect to the approach speeds of parts of the human body.

EN 1037: Safety of machinery. Prevention of unexpected start-up.

EN 574: Safety of machinery. Two-hand control devices. Functional aspects. Principles for design.

EN 60947-1 (equivalent to IEC 60947-1): Low-voltage switchgear and controlgear. Part 1: General rules.

EN 60947-5-1 (equivalent to IEC 60947-5-1): Low-voltage switchgear and controlgear. Part 5: Devices for control and operation circuits. Section 1: Electromechanical control circuit devices.

EN 60947-5-2: Low-voltage switchgear and controlgear. Part 5-2: Control circuit devices and switching elements - Proximity switches

EN 60947-5-3: Low-voltage switchgear and controlgear. Part 5-3: Control circuit devices and switching elements - Requirements for proximity devices with defined behaviour under fault conditions (PDF)

EN 60204-1 (equivalent to IEC 60204-1): Safety of machinery. Electrical equipment of machines. Part 1: General rules.

EN 60529 (equivalent to IEC 60529): Protection degree of the housings (IP codes).

EN 62326-1 (equivalent to IEC 62326-1): Printed boards. Part 1: Generic specification

EN 60664-1 (equivalent to IEC 60664-1): Insulation coordination for equipment within low-voltage systems Part 1: Principles, requirements and tests.

EN 61508 (equivalent to IEC 61508): Functional safety of electrical, electronic and programmable electronic systems for safety applications.

EN 62061 (equivalent to IEC 62061): Safety of machinery - Functional safety of safety-related electrical, electronic and programmable electronic control systems.

EN 60079-0 (equivalent to IEC 60079-0): Electrical apparatus for potentially explosive atmospheres. General rules

EN 60079-11 (equivalent to IEC 60079-11): Electrical apparatus for potentially explosive atmospheres. Intrinsic safety "i"

EN 60079-31 (equivalent to IEC 60079-31): Electrical apparatus for potentially explosive atmospheres. Type of protection "n"

EN 60079-28 (equivalent to IEC 60079-28): Electrical apparatus for use in the presence of combustible dust. Part 1-1: construction and testing

BG-GS-ET-15: Prescriptions about how to test switches with forced contact opening to be used in safety applications (German standard).

UL 508: Standard for industrial control equipment. (American standard).

CSA 22-2 no. 14: Standard for industrial control equipment. (Canadian standard).

European directives

2006/95/EC	Directive on low-voltage switchgear and controlgear
2006/42/EC	Machinery Directive
2004/108/EC	Directive on electromagnetic compatibility
94/9/EC	ATEX Directive

Regulatory Organisations

CEI	Comitato Elettrotecnico Italiano (IT)	NF	Normes Françaises (FR)
CSA	Canadian Standard Association (CAN)	VDE	Verband Deutscher Elektrotechniker (DE)
CENELEC	European Committee for Electrotechnical Standardisation	UNI	Ente Nazionale Italiano di Unificazione (IT)
CEN	European Committee for Standardisation	UL	Underwriter's Laboratories (USA)
IEC	International Electrotechnical Commission	TUV	Technischer Überwachungs-Verein (DE)

Protection degree of the housings for electrical material according to IEC 60529

This table indicates the protection degrees according to IEC 60529, EN 60529, CEI 70-1 standards.

The degrees are identified by the letters IP and 2 numbers. 2 more letters can be added, in order to give the protection degree for people or other features. The first number means the degree of protection against penetration of external solid materials. The second one indicates the degree of protection against penetration of water.

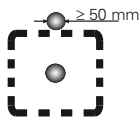
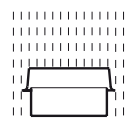
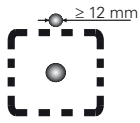
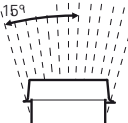
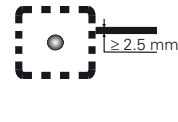
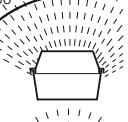
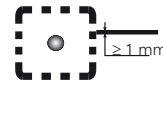
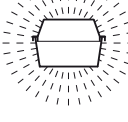
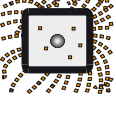
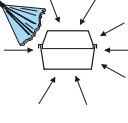
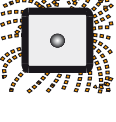
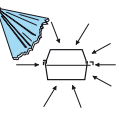
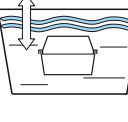
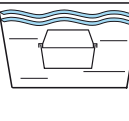
1st number	Description	Protection for the machine	Protection for persons	2nd number	Description	Protection for persons
0		Not protected	Not protected	0		Not protected
1		Protected from solid bodies of more than 50 mm in diameter	No access to hazardous parts with back of the hands (Ø 50 mm)	1		Protected from drops of water falling vertically
2		Protected from solid bodies of more than 12 mm in diameter	No access to hazardous parts with a finger (Ø 12 mm)	2		Protected from drops of water at an angle of 15° max.
3		Protected from solid bodies of more than 2.5 mm in diameter	No access to hazardous parts with tool (Ø 2.5 mm)	3		Protected from drops of water at an angle of 60° max.
4		Protected from solid bodies of more than 1 mm in diameter	No access to hazardous parts with wire (Ø 1 mm)	4		Protected from splashes of water around it
5		Protected from dust	No access to hazardous parts with wire (Ø 1 mm)	5		Protected from jets of water discharged around it
6		Totally protected from dust	No access to hazardous parts with wire (Ø 1 mm)	6		Protected from strong jets of water around it
				7		Protected from temporary water immersion (30 minutes in a depth of one meter)
				8		Protected from continuous water immersion by aggrement

Protection degree IP69K according to ISO 20653

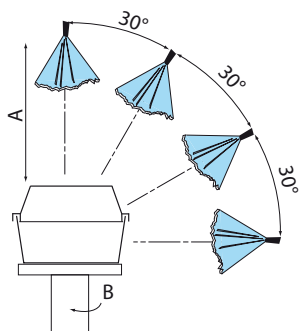

ISO 20653 provides a particularly stringent test. The standard provides that a device has to pass a particularly heavy test which simulates the conditions of pressure washing in industrial environments with water jets having pressure between 80 and 100 bar, flow rate between 14 and 16 l/min. and temperature 80°C.

Test specifications:

Rotation speed (B): 5 ± 1 rpm
 Distance from water jet (A): $100 +50/-0$ mm
 Water flow rate: 15 ± 1 l/min
 Water pressure: 9000 ± 1000 kPa
 Water temperature: $80 \pm 5^\circ\text{C}$
 Test duration: 30 s each position

Housing features in accordance with UL (UL 508) and CSA (C22-2 no.14) approvals

The features required for a housing are determined by a specific environmental designation and other features like the kind of gasket or the use of solvent materials.

Type	Use guidance and description
1	Mainly for indoor utilization, supplied with protection against contact with the internal mechanism and against a limited quantity of falling dirt.
4X	Both indoor and open-air utilization, supplied with a protection degree against falling rain, sprinkling of water and direct water from the pipe. It is not damaged by the freezing of the housing and is rust-proof. Resistant against corrosion.
12	Indoor utilization, supplied with a protection degree against dust, dirt, flying fibres, dripping water and outside condensation of non-corrosive fluids.
13	Indoor utilization, supplied with a protection degree against gauze, dust penetration, outside condensation and sprinkling of water, oil and non-corrosive fluids.

Pollution degree (of environmental conditions) according to EN 60947-1

According to the standard IEC 60947-1, the pollution degree is a conventional number based on the quantity of conducting hygroscopic dust, ionized gas or salt, on the relative humidity and on the frequency of occurrence, which is translated into hygroscopic absorption or humidity condensation, having the effect of reducing the dielectric rigidity and/or surface resistivity. In equipment to be used inside a housing or having an integral enclosure as part of the device, the pollution degree applies to the inner part of housing. With the purpose of evaluating the air and surface insulation distances, the following four pollution degrees are defined:

Degree	Description
1	No pollution or only dry and non-conductive pollution occurs.
2	Normally, only non-conductive pollution is present. Occasionally some temporary conductivity caused by condensation may occur.
3	Some conductive pollution is present, or some dry non-conductive pollution that becomes conductive because of condensation.
4	Pollution causes persistent conductivity, for instance because of conductive dust or rain or snow.

Where not otherwise specified by the applicable standard for the product, equipment for industrial applications are generally intended for their use in environment with pollution degree 3. Nevertheless, other degrees can be considered, depending on the micro-environment or on the particular applications.

Utilization categories for switching elements according to EN 60947-5-1

Alternate current utilization

Utilization category	Description
AC12	Control of resistive loads and solid state loads with insulation by optocouplers.
AC13	Control of solid state loads with transformer isolation
AC14	Control of electromagnetic loads, power ≤ 72 VA
AC15	Control of electromagnetic loads, power ≥ 72 VA

Direct current utilization

Utilization category	Destination
DC12	Control of resistive loads and solid state loads with insulation by optocouplers.
DC13	Control of electromagnet loads without economy resistors in circuit
DC14	Control of electromagnet loads with economy resistors in circuit