

Selection diagram

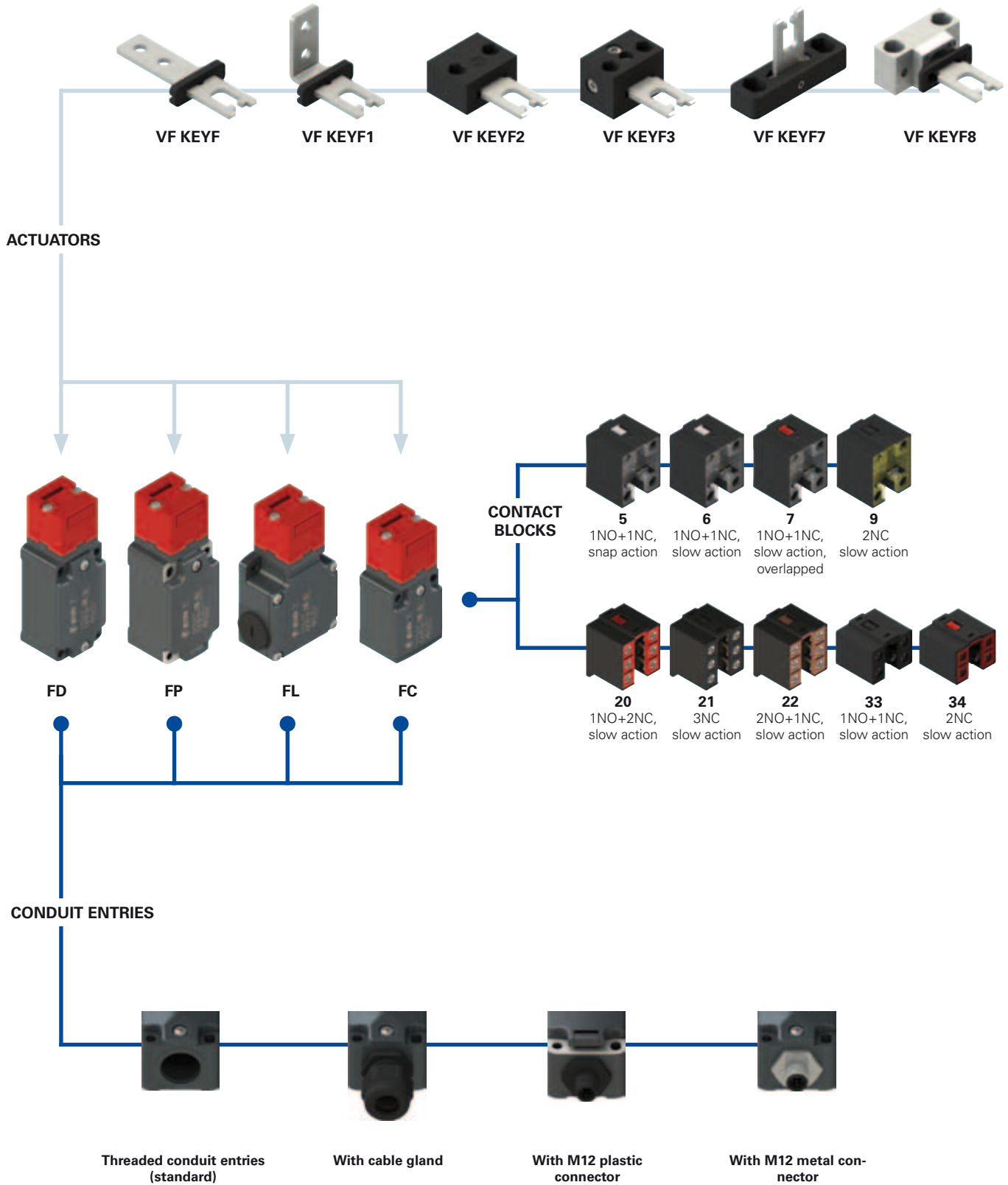

—●— product option
 —▶— accessory sold separately



Code structure **Attention!** The feasibility of a code number does not mean the effective availability of a product. Please contact our sales office.

article options options
FD 693-F1GM2K50T6

Housing	
FD	metal, one conduit entry
FL	metal, three conduit entries
FP	technopolymer, one conduit entry

Contact blocks	
5	1NO+1NC, snap action
6	1NO+1NC, slow action
7	1NO+1NC, slow action, overlapped
9	2NC, slow action
20	1NO+2NC, slow action
21	3NC, slow action
22	2NO+1NC, slow action
33	1NO+1NC, slow action
34	2NC, slow action

Actuators	
	without actuator (standard)
F	straight actuator VF KEYF
F1	angled actuator VF KEYF1
F2	jointed actuator VF KEYF2
F3	jointed actuator adjustable in two directions VF KEYF3
F7	jointed actuator adjustable in one direction VF KEYF7
F8	universal actuator VF KEYF8

Ambient temperature	
	-25°C ... +80°C (standard)
T6	-40°C ... +80°C

Pre-installed cable glands or connectors	
	without cable gland or connector (standard)
K23	cable gland for cables Ø 6...Ø 12 mm
...
K50	M12 metal connector, 5 poles
...

Please contact our technical service for the complete list of possible combinations.

Threaded conduit entry	
M2	M20x1.5 (standard)
	PG13.5

Contact type	
	silver contacts (standard)
G	silver contacts with 1 µm gold coating

article options options
FC 3393-F1GM2K50T6

Housing	
FC	metal, one conduit entry

Contact blocks	
33	1NO+1NC, slow action
34	2NC, slow action

Actuators	
	without actuator (standard)
F	straight actuator VF KEYF
F1	angled actuator VF KEYF1
F2	jointed actuator VF KEYF2
F3	jointed actuator adjustable in two directions VF KEYF3
F7	jointed actuator adjustable in one direction VF KEYF7
F8	universal actuator VF KEYF8

Ambient temperature	
	-25°C ... +80°C (standard)
T6	-40°C ... +80°C

Pre-installed cable glands or connectors	
	without cable gland (standard)
K23	cable gland for cables Ø 6...Ø 12 mm
K50	M12 metal connector, 5 poles

Threaded conduit entry	
M2	M20x1.5 (standard)
	PG11

Contact type	
	silver contacts (standard)
G	silver contacts with 1 µm gold coating

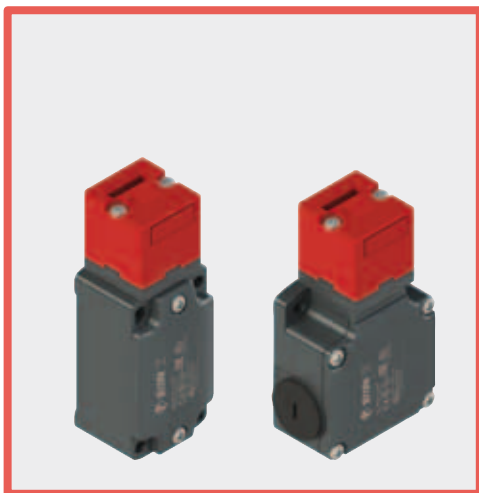

Main features

- Metal housing or technopolymer housing, from one to three conduit entries
- Protection degree IP67
- 9 contact blocks available
- 6 stainless steel actuators available
- Versions with M12 connector
- Versions with gold-plated silver contacts

Markings and quality marks:



IMQ approval:	EG605
UL approval:	E131787
CCC approval:	2007010305230000 (FD-FL-FC series) 2007010305230014 (FP series)
EAC approval:	RU C-IT ДМ94.В.01024

Technical data

Housing

FP series housing made of glass fiber reinforced technopolymer, self-extinguishing, shock-proof and with double insulation: □

FD, FL and FC series: metal housing, baked powder coating.

Metal head, baked powder coating.

FD, FP, FC series: one threaded conduit entry: M20x1.5 (standard)

FL series - three threaded conduit entries: M20x1.5 (standard)

Protection degree: IP67 acc. to EN 60529 with cable gland of equal or higher protection degree

General data

For safety applications up to: SIL 3 acc. to EN 62061
PL e acc. to EN ISO 13849-1
type 2 acc. to EN ISO 14119
Low acc. to EN ISO 14119

Mechanical interlock, coded:

Coding level:

Safety parameters:

B_{10d} : 2,000,000 for NC contacts

Service life: 20 years

Ambient temperature: -25°C ... +80°C

Max. actuation frequency: 3600 operating cycles¹/hour

Mechanical endurance: 1 million operating cycles¹

Max. actuation speed: 0.5 m/s

Min. actuation speed: 1 mm/s

Tightening torques for installation: see pages 297-308

(1) One operation cycle means two movements, one to close and one to open contacts, as defined in EN 60947-5-1.

Cable cross section (flexible copper strands)

Contact blocks 20, 21, 22, 33, 34:	min.	1 x 0.34 mm ²	(1 x AWG 22)
	max.	2 x 1.5 mm ²	(2 x AWG 16)
Contact blocks 5, 6, 7, 9:	min.	1 x 0.5 mm ²	(1 x AWG 20)
	max.	2 x 2.5 mm ²	(2 x AWG 14)

In conformity with standards:

IEC 60947-5-1, EN 60947-5-1, EN 60947-1, IEC 60204-1, EN 60204-1, EN ISO 14119, EN ISO 12100, IEC 60529, EN 60529, BG-GS-ET-15, UL 508, CSA 22.2 No.14.

Approvals:

IEC 60947-5-1, UL 508, CSA 22.2 No.14, GB14048.5-2001.

In conformity with the requirements of:

Low Voltage Directive 2006/95/EC, Machinery Directive 2006/42/EC and EMC Directive 2004/108/EC.

Positive contact opening in conformity with standards:

IEC 60947-5-1, EN 60947-5-1

⚠ If not expressly indicated in this chapter, for correct installation and utilization of all articles see chapter utilization requirements from page 297 to page 308.

	Electrical data	Utilization category
without connector	Thermal current (I _{th}):	10 A
	Rated insulation voltage (U _i):	500 Vac 600 Vdc 400 Vac 500 Vdc (contact blocks 20, 21, 22, 33, 34)
	Rated impulse withstand voltage (U _{imp}):	6 kV 4 kV (contact blocks 20, 21, 22, 33, 34)
	Conditional short circuit current: Protection against short circuits: Pollution degree:	1000 A acc. to EN 60947-5-1 type aM fuse 10 A 500 V 3
with M12 connector 4 or 5 poles	Thermal current (I _{th}):	4 A
	Rated insulation voltage (U _i):	250 Vac 300 Vdc
	Protection against short circuits: Pollution degree:	type gG fuse 4 A 500 V 3
	Utilization category:	Alternating current: AC15 (50÷60 Hz) U _e (V) 250 400 500 I _e (A) 6 4 1 Direct current: DC13 U _e (V) 24 125 250 I _e (A) 6 1.1 0.4
with M12 connector 8 poles	Thermal current (I _{th}):	2 A
	Rated insulation voltage (U _i):	30 Vac 36 Vdc
	Protection against short circuits: Pollution degree:	type gG fuse 2 A 500 V 3
	Utilization category:	Alternating current: AC15 (50÷60 Hz) U _e (V) 24 I _e (A) 2 Direct current: DC13 U _e (V) 24 I _e (A) 2



Description



These safety switches are ideal for controlling gates, sliding doors and other guards which protect dangerous parts of machines without inertia.

The stainless steel actuator is fastened to the moving part of the guard, so it is removed from the switch on every opening of the guard. The switch mechanism guarantees that removing the actuator forces the positive opening of the electrical contacts. Easy to install, these switches can be applied to any kind of protection (with hinge, sliding and removable ones). Besides, the possibility to actuate the switch only with its actuator guarantees that the machine can be restarted only when the guard has been closed. Made of rugged materials and with oversized thickness, these switches are designed for the use on heavy guards.

Orientable heads

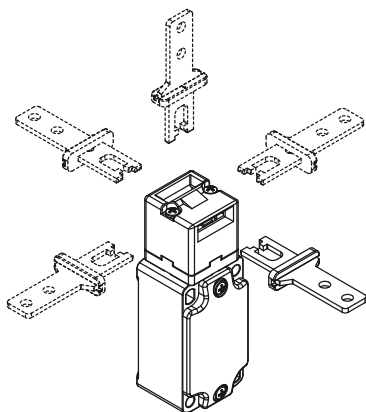

Removing the two fastening screws, in all switches, the head can be rotated in 90° steps. In this way it is possible to actuate the switch from 5 different directions.

Wide-ranging actuator travel

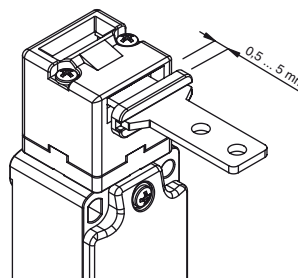

The head of this switch is equipped with an actuator with a wide range of travel. In this way the guard can oscillate along the direction of insertion (4.5mm) without causing unwanted machine shutdowns. This extensive travel is available in all actuators, in order to ensure maximum device reliability.

Protection degree IP67

IP67

These devices are designed to be used in the toughest environmental conditions and they pass the IP67 immersion test acc. to IEC 60529.

They can therefore be used in all environments where the maximum protection of the housing is required.

Safety screws for actuators

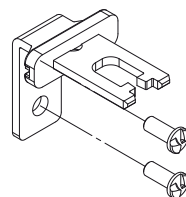

As required by EN ISO 14119, the actuator must be fixed immovably to the door frame. Pan head safety screws with one-way fitting are available for this purpose. With this screw type, the actuators cannot be removed or tampered with using common tools. See accessories on page 295.

Extended temperature range

-40°C

This range of switches is also available in a special version with an ambient operating temperature range of -40°C to +80°C.

They can be used for applications in cold stores, sterilisers and other devices with low temperature environments. Special materials that have been used to realize these versions, maintain unchanged their features also in these conditions, widening the installation possibilities.

Laser engraving



All devices are indelibly marked with a dedicated laser system that allows the marking to be also suitable for extreme environments. This system that does not use labels, prevents the loss of plate data and the marking is more resistant over time.

Characteristics approved by IMQ

Rated insulation voltage (Ui): 500 Vac
400 Vac (for contact blocks 20, 21, 22, 33, 34)
Conventional free air thermal current (Ith): 10 A
Protection against short circuits: type aM fuse 10 A 500 V
Rated impulse withstand voltage (U_{imp}): 6 kV
4 kV (for contact blocks 20, 21, 22, 33, 34)
Protection degree of the housing: IP67
MV terminals (screw terminals)
Pollution degree 3
Utilization category: AC15
Operating voltage (Ue): 400 Vac (50 Hz)
Operating current (Ie): 3 A
Forms of the contact element: Zb, Y+Y, Y+Y+X, Y+Y+Y, Y+X+X
Positive opening of contacts on contact blocks 5, 6, 7, 9, 20, 21, 22, 33, 34

In conformity with standards: EN 60947-1, EN 60947-5-1+ A1:2009, fundamental requirements of the Low Voltage Directive 2006/95/EC.

Please contact our technical service for the list of approved products.

Characteristics approved by UL

Utilization categories Q300 (69 VA, 125 ... 250 Vdc)
A600 (720 VA, 120 ... 600 Vac)
Data of housing type 1, 4X "indoor use only", 12, 13
For all contact blocks use 60 or 75 °C copper (Cu) conductor, rigid or flexible, wire size AWG 12-14. Terminal tightening torque of 7.1 lb in (0.8 Nm).

In conformity with standard: UL 508, CSA 22.2 No.14.

Please contact our technical service for the list of approved products.

Dimensional drawings

All measures in the drawings are in mm

Contact type:

- R** = snap action
- L** = slow action
- LO** = slow action overlapped

Contact blocks

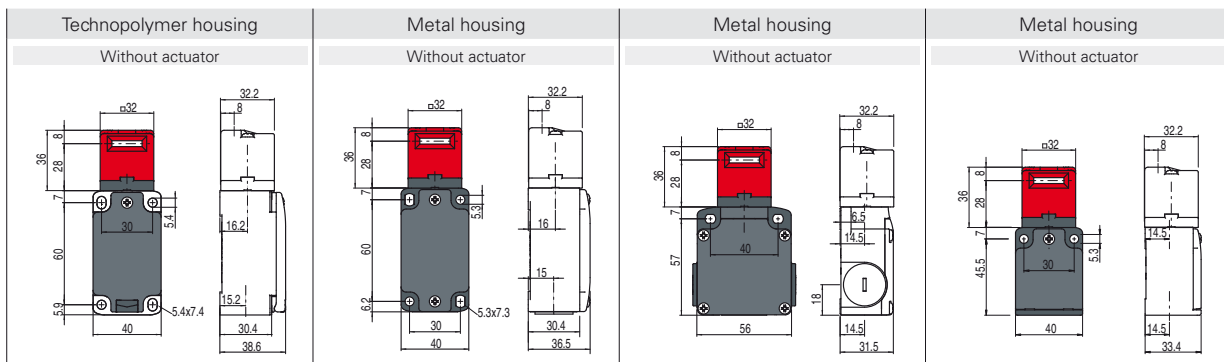

	Technopolymer housing Without actuator	Metal housing Without actuator	Metal housing Without actuator	Metal housing Without actuator
5 R	FP 593-M2 ⊕ 1NO+1NC 	FD 593-M2 ⊕ 1NO+1NC 	FL 593-M2 ⊕ 1NO+1NC 	
6 L	FP 693-M2 ⊕ 1NO+1NC 	FD 693-M2 ⊕ 1NO+1NC 	FL 693-M2 ⊕ 1NO+1NC 	
7 LO	FP 793-M2 ⊕ 1NO+1NC 	FD 793-M2 ⊕ 1NO+1NC 	FL 793-M2 ⊕ 1NO+1NC 	
9 L	FP 993-M2 ⊕ 2NC 	FD 993-M2 ⊕ 2NC 	FL 993-M2 ⊕ 2NC 	
20 L	FP 2093-M2 ⊕ 1NO+2NC 	FD 2093-M2 ⊕ 1NO+2NC 	FL 2093-M2 ⊕ 1NO+2NC 	
21 L	FP 2193-M2 ⊕ 3NC 	FD 2193-M2 ⊕ 3NC 	FL 2193-M2 ⊕ 3NC 	
22 L	FP 2293-M2 ⊕ 2NO+1NC 	FD 2293-M2 ⊕ 2NO+1NC 	FL 2293-M2 ⊕ 2NO+1NC 	
33 L	FP 3393-M2 ⊕ 1NO+1NC 	FD 3393-M2 ⊕ 1NO+1NC 	FL 3393-M2 ⊕ 1NO+1NC 	FC 3393-M2 ⊕ 1NO+1NC
34 L	FP 3493-M2 ⊕ 2NC 	FD 3493-M2 ⊕ 2NC 	FL 3493-M2 ⊕ 2NC 	FC 3493-M2 ⊕ 2NC
Min. force	10 N (18 N ⊕)	10 N (18 N ⊕)	10 N (18 N ⊕)	10 N (18 N ⊕)

How to read travel diagrams

All measures in the diagrams are in mm

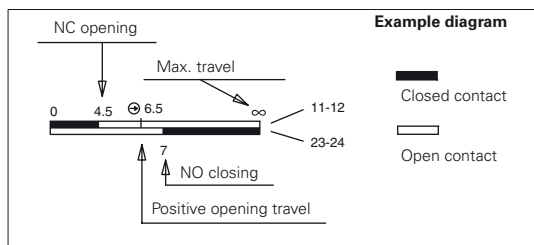

IMPORTANT:
NC contact has to be considered with inserted actuator. In **safety applications**, actuate the switch **at least up to the positive opening travel** shown in the travel diagrams with symbol ⊕. Operate the switch **at least with the positive opening force**, indicated between brackets below each article, aside the minimum force value.

Utilization limits

Do not use where dust and dirt may penetrate in any way into the head and deposit there, in particular where metal dust, concrete or chemicals are spread. Adhere to the EN ISO 14119 requirements regarding low level of coding for interlocks. Do not use in environments with the presence of explosive or flammable gas. In these cases, use ATEX products (check the specific Pizzato catalogue).



Stainless steel actuators

All measures in the drawings are in mm

IMPORTANT: These actuators can be used with items of the FD, FP, FL, FC and FS series only (e.g. FD 693-M2).
Low level of coding acc. to EN ISO 14119.

Article	Description
VF KEYF	Straight actuator

Article	Description
VF KEYF1	Angled actuator

Article	Description
VF KEYF2	Jointed actuator

The actuator can flex in four directions for applications where the door alignment is not precise.

Article	Description
VF KEYF3	Actuator adjustable in two directions

Actuator adjustable in two directions for doors with reduced dimensions.

Article	Description
VF KEYF7	Actuator adjustable in one direction

Actuator adjustable in one direction for doors with reduced dimensions.

Article	Description
VF KEYF8	Universal actuator

Joined and two directions adjustable actuator for doors with reduced dimensions.

The actuator has two couples of fixing holes and it is possible to rotate by 90° the actuator-working plan.
Body material: zinc alloy

Accessories

Article	Description
VF KB1	Actuator entry locking device

Padlockable device to lock the actuator entry in order to prevent from the accidental closing of the door behind operators while they are inside the machine.

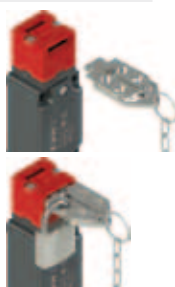

Items with code on **green** background are stock items

Accessories See page 287

→ The 2D and 3D files are available at www.pizzato.com