

Selection diagram

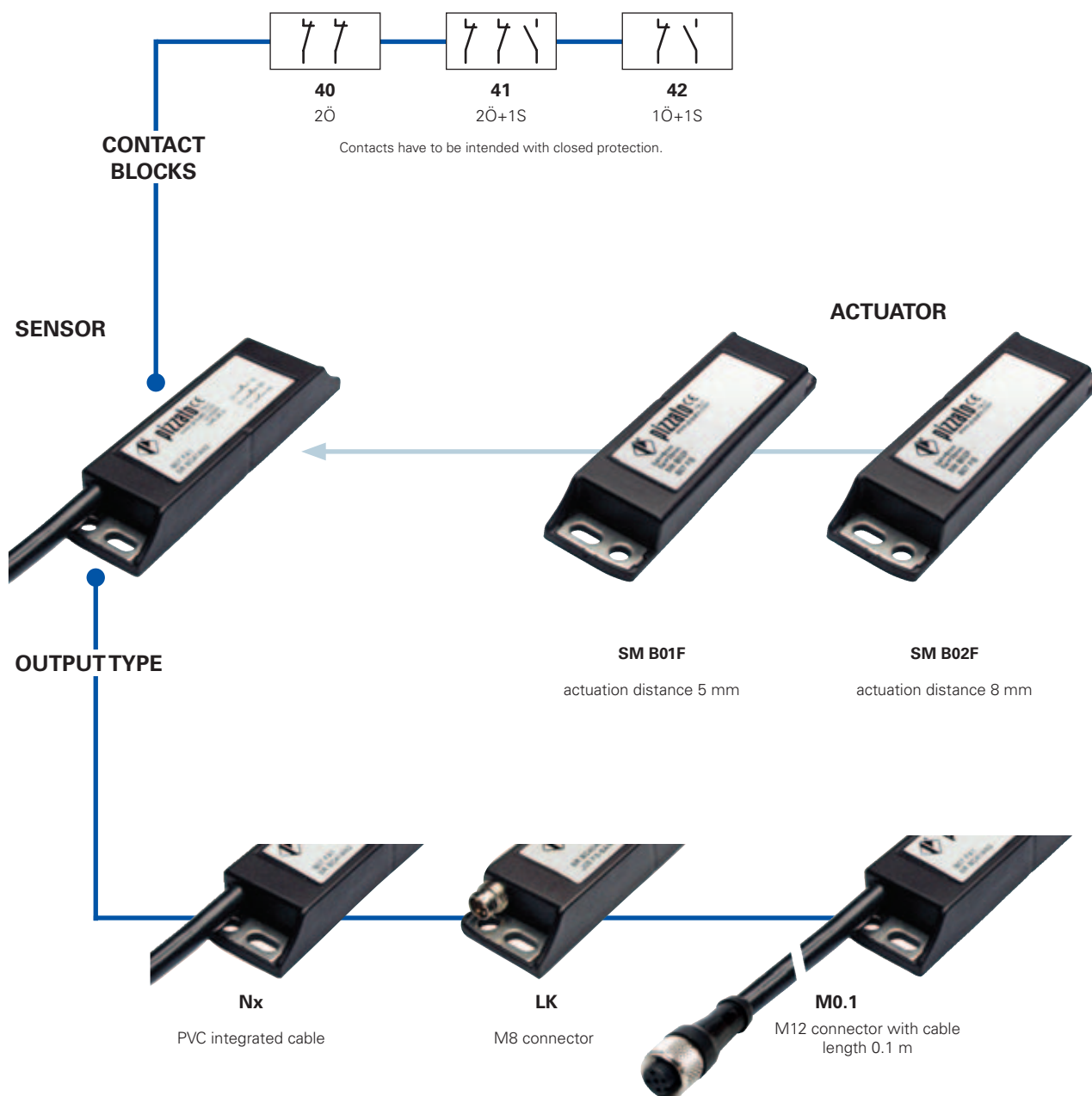

—●— product option
 —▶— accessory sold separately



NEW New features 2009

IP69K

Protection degree IP69K for SR series

- Protection degree IP69K according to standard DIN 40050 part 9
- Suitable for use in machineries subjected to intense washings, such as in the food or pharmaceutical industry

NEW New features 2009



Approval UL for SR series

Sensor with actuator code structure

SR BD40AN2-B01F

Sensor housing		Actuator	
SR	polymer housing	B01F	complete with SM B01F actuator, actuation distance 5 mm
		B02F	complete with SM B02F actuator, actuation distance 8 mm
Contacts (with closed protection)		Type of cable or connector	
40	2NC	N1	integrated PVC cable, length 1 m
41	1NO+2NC	N2	integrated PVC cable, length 2 m
42	1NO+1NC
		N10	Integrated PVC cable, length 10 m
		M0.1	M12 connector with cable length 0.1 m
		LK	M8 connector (available with 40 and 42 contacts only)

Single sensor code structure

SR BD40AN2

Sensor housing		Type of cable or connector	
SR	polymer housing	N1	integrated PVC cable, length 1 m
		N2	integrated PVC cable, length 2 m
	
		N10	Integrated PVC cable, length 10 m
		M0.1	M12 connector with cable length 0.1 m
		LK	M8 connector (available with 40 and 42 contacts only)
Contacts (with closed protection)			
40	2NC		
41	1NO+2NC		
42	1NO+1NC		

Actuator code structure

SM B01F

Actuator	
B01F	actuation distance 5 mm
B02F	actuation distance 8 mm

- 1
- 1A
- 1B
- 2
- 2A
- 2B
- 2C
- 2D
- 2E
- 3
- 3A
- 3B
- 3C
- 4
- 4A
- 4B**
- 4C
- 4D
- 4E
- 4F
- 4G
- 4H
- 5
- 6



Main data

- Long life, no mechanical wear
- Stainless steel fixing plates
- Output contacts: 2NC, 1NO+2NC or 1NO+1NC
- Insensitive to dirt
- Protection degree IP67 and IP69K
- Coded actuator
- Polymer housing
- Versions with M8 or M12 connector

Markings and quality marks:



Approval UL:

E131787

In conformity with requirements requested by:

Low Voltage Directive 2006/95/EC
Machinery Directive 2006/42/EC
Electromagnetic Compatibility 2004/108/EC.

Technical data

Housing

Made of glass-reinforced polymer, self-extinguishing, shock-proof thermoplastic resin. Version with integrated cable with 4 or 6 x 0.25 mm² wires length 2 m, other lengths on request.

Versions with M8 or M12 connector

Protection degree:

IP67 according to EN 60529
IP69K according to DIN 40050
88 x 25 x 13 mm

Dimensions L x P x H:

General data

Safety parameters: see page 6/32
Ambient temperature: -20°C ... +80°C
Vibrations holding: 10 gn (10...500 Hz) according to IEC 60068-2-6
Shock holding: 30 gn (11 ms) according to IEC 60068-2-27
Pollution degree: 3
Max screw driving torque: 0,8 ... 2 Nm

In conformity with standards:

IEC 60947-1, EN 60947-1, IEC 60947-5-1, EN 60947-5-1, EN 60947-5-2, EN 60947-5-3 (in connection with safety module), EN 1088, EN ISO 14119, EN ISO 12100-1, EN ISO 12100-2, EN ISO 13849-1, EN ISO 13849-2, IEC 60204-1, EN 60204-1, IEC 60529, EN 60529.

Approvals:

UL 508

Actuating data

Assured operating distance Sao: 5 mm with actuator SM B01F
Assured release distance Sar: 15 mm with actuator SM B01F
Assured operating distance Sao: 8 mm with actuator SM B02F
Assured release distance Sar: 20 mm with actuator SM B02F
Repeat accuracy: ≤ 10%
Frequency of operating cycles: 150 Hz
Distance between two sensors: Min. 50 mm

Electrical data

Rated insulation voltage Ui: 120 Vac (with cable)
60 Vac / 75 Vdc (with M8 connector)
120 Vac (with 4 poles M12 connector)
30 Vac / 36 Vdc (with 8 poles M12 connector)
Thermal current Ith: 0.5 A
Max switching load: 6 W (resistive load)
Rated operational voltage (Ue): 24 Vac/DC
Rated operational current (Ie): 0.5 A (resistive load)
Protection fuse: 0.5 A type F
Electrical endurance: 1 million operations cycles

Connection with safety modules with personnel protection function:

Connection with safety modules CS AR-08; CS AR-05; CS AR-06; CS AT-0; CS AT-1; CS AT-2

The sensor connected with the safety module can be classified as device for control circuit up to PDF-M (EN 60947-5-3). The system can be used in safety circuits up to category 4 according to EN 954-1.

Data type approved by UL

Utilization categories: 24 Vdc, 0,25 A (resistive load)

Data of the housing type 1, 4X "indoor use only", 12

Accessory of series CS.

In conformity with standard: UL 508

Please contact our technical service for the list of approved products.



Introduction

Coded magnetic sensors are devices studied to monitor protections and guards that, when linked to a safety module, can create a system with safety category up to SIL 3 according to EN 62061, up to PLe according to EN ISO 13849-1 and up to category 4 according to EN 954-1. These products are composed by a magnetic field monitoring sensor, which is connected to the machine structure; and by a coded magnetic actuator, which has to be connected to the mobile guards. When sensor and actuator are neared (closed guard), the sensor recognizes the actuator and provides to actuate electric contacts. The sensor is manufactured to be activated only by the correct coded actuator and not through a common magnet.

Insensitivity to dirt

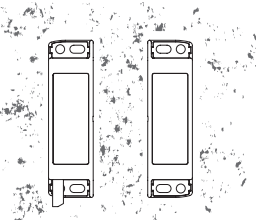

Magnetic sensors are totally sealed and maintain unchanged their safety characteristics also where dirt and dust are present (not ferromagnetic material).

This characteristic, joined with the shape without recesses, make them especially proper to be used in the food-industrial sector.

Stainless steel fixing plates

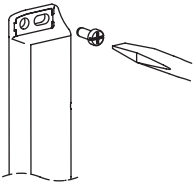

In order to avoid that the fixing on no perfectly plane surfaces could damage the fixing slots, Pizzato Elettrica magnetic sensors are provided with stainless steel fixing plates.

Also in presence of right fixing surfaces, this solution makes the sensor stronger to mechanical stresses and so the whole system becomes safer and more reliable.

Alignment marks

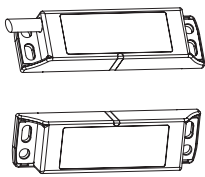

Sensors and magnets are provided with marks on the housing, as reference for operating distances. For a correct working, it is necessary install sensor with facing marks (see figure).

Wide actuation zone

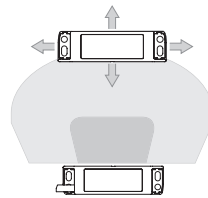

Because of their intrinsic characteristics, magnetic sensors have a wide actuation zone, which make them appreciated in the use of inaccurate protections or for protection that can change their mechanic characteristics through the time.

In this type of sensors actuation distances may change according to the actuator displacement direction from the sensor.

Actuation from many directions

Pizzato Elettrica magnetic sensors have been designed in order to be activated by the related actuator from many directions. In this way, the customer has the max flexibility about the placing of the devices along the protections perimeters.

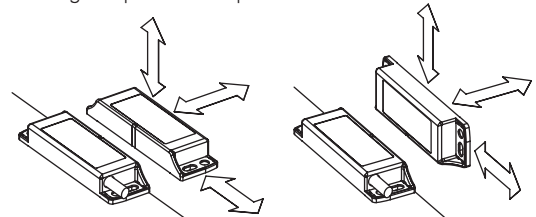

Coded magnetic sensors used for safety applications

A coded magnetic sensor alone can not be used for safety functions because its working principles are not considered safe by the standards (as are, for example, the positive opening on mechanical switches). For this reason a coded magnetic sensor, in order to be used in safety applications, has to be compulsory connected to a proper safety module which monitors its right working.

Complete safety system

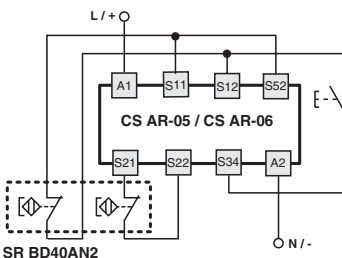

These magnetic sensors have been checked and tested for working with proper Pizzato Elettrica safety modules. Using completed and tested solutions, the customer has the certainty to have no electric incompatibility between sensor and safety module, and has a higher reliability guarantee.

Sensors	Compatible safety modules	Safety module output contacts
SR BD40A●● SR BD41A●●	CS AR-05●●●●	3NO+1NC
	CS AR-06●●●●	3NO+1NC
	CS AR-08●●●●	2NO
	CS AT-0●●●●	2NO+1NO (ist. cont.)+2NO (del. cont.)
	CS AT-1●●●●	3NO (ist. cont.)+2NO (del. cont.)
	CS AT-2●●●●	2NO (ist. cont.)+1NO (del. cont.)

Connection of sensors and switches in series

Pizzato Elettrica magnetic sensors could be connected in series with the only limitation that the overall resistance, gave by sensors and the related wiring, has to be not higher than the admitted max value of the module, which typically is equal to 50 ohm (see module features). It is a very high value that, with normal wiring, it allows the use of dozens of sensors without problems. It is also possible to realize mixed circuit solutions connecting in series magnetic sensor to safety switches, with the only limitation of the above mentioned max electric resistance.

We remind you that connection in series of two or more coded sensors reduce the system self-monitoring capacity which passes to category 3 in conformity with EN 954-1.

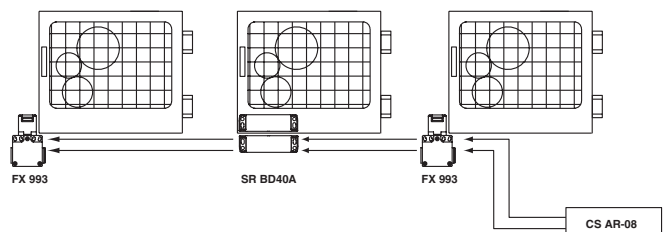

For safety modules technical data see page 4/123

Wiring with safety modules

Wiring with safety modules CS AR-05 or CS AR-06

Input configuration with manual start (CS AR-05) and monitored start (CS AR-06)

2 channels

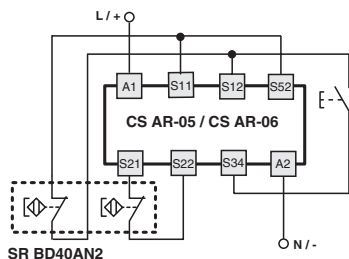

Wiring with safety module CS AR-08 or CS AT

Input configuration with manual start

2 channels

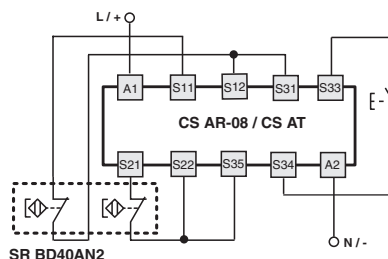

For safety modules technical data see page 4/123

Internal connections

Contacts imply closed protection

With cable (2NC)

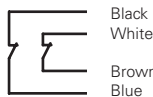

With cable (1NC+1NO)

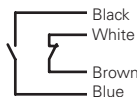

With cable (2NC+1NO)



With M8 connector (2NC)



With M8 connector (1NC+1NO)

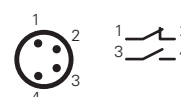

With M12 connector (2NC+1NO)



With M12 connector (2NC)



With M12 connector (1NC+1NO)



Intervention distance SR BD.....-B01F

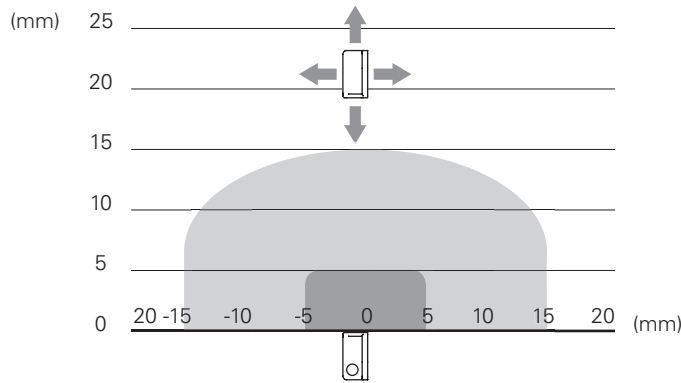
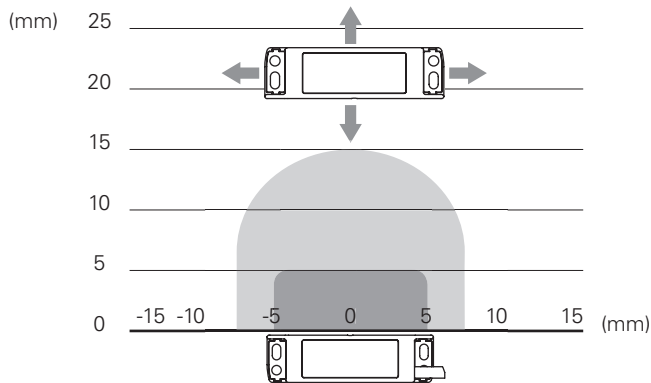

Intervention distance SR BD.....-B02F

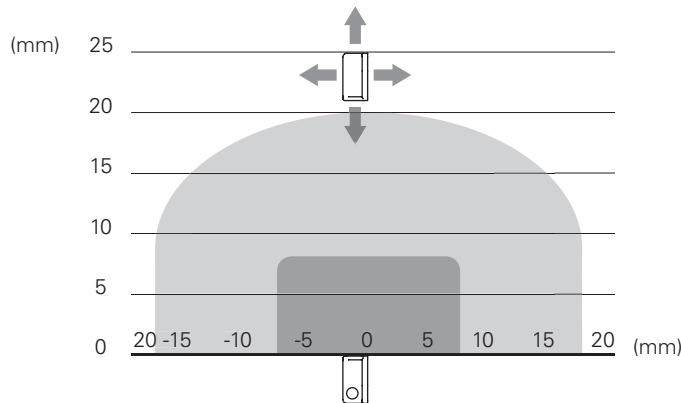
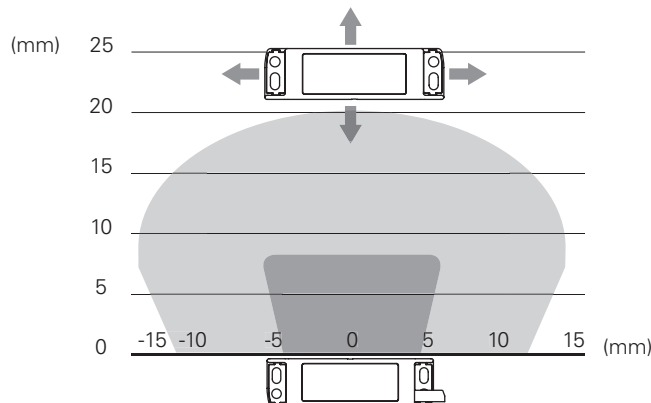

Legend:

Assured operating distance Sao

Assured release distance Sar

Note: The drawing of the activation areas is indicative.



Dimensional drawings

Sensor with cable, length 2 m		Sensor with M8 connector		M12 connector with cable length 0.1 m		Coded actuator	
SR BD40AN2	2NC	SR BD40ALK	2NC	SR BD40AM0.1	2NC	SM B01F	Actuation distance 5 mm
SR BD41AN2	1NO+2NC	SR BD41ALK	2NC	SR BD41AM0.1	1NO+2NC	SM B02F	Actuation distance 8 mm
SR BD42AN2	1NO+1NC	SR BD42ALK	1NO+1NC	SR BD42AM0.1	1NO+1NC		

Utilization limits

- The installation must be performed by qualified staff only.
- Before installation and at regular interval, check the right contacts switching and the system operation of the sensor and the associated safety module.
- Do not use a hammer for adjustment.
- Do not use the sensor as a mechanical stop.
- Observe the assured operating and release distances.
- It is advisable to make adjustment observing the diagram reported in the switching distances section.
- Do not install the sensor and the actuator on strong magnetic field.
- Keep away from iron filing.

Shock, vibrations and wear:

- Do avoid impact with the sensor. Excessive shock and vibrations could not guarantee the right working of the sensor.
- The actuator must not strike sensor.
- In case of damages or wear is necessary to change the whole device, included the actuator.

Warning during the wiring:

- Keep load under the value indicated in the electrical data.
- When the sensor contacts are used without the respective safety module, connect in series to each contact the protection fuse indicated in the electrical data.
- Turn off the power supply before check the switch connection contacts, also during the wiring.

Multiple systems sensor-actuator assembly

The minimum mounting gap between sensor-actuator systems must be at least 50 mm.

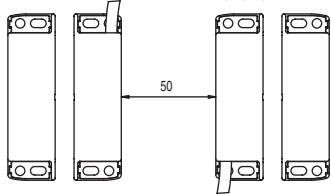

Installation on ferromagnetic material

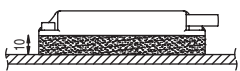

- If possible do not mount the sensor and the actuator on ferromagnetic materials.
- In order to avoid switching distances reductions, use a non-magnetic shim minimum thickness ≥ 10 mm.

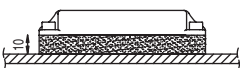

Accessories See page 5/1

All measures in the drawings are in mm

Items with code on the **green** background are available in stock

Selection diagram

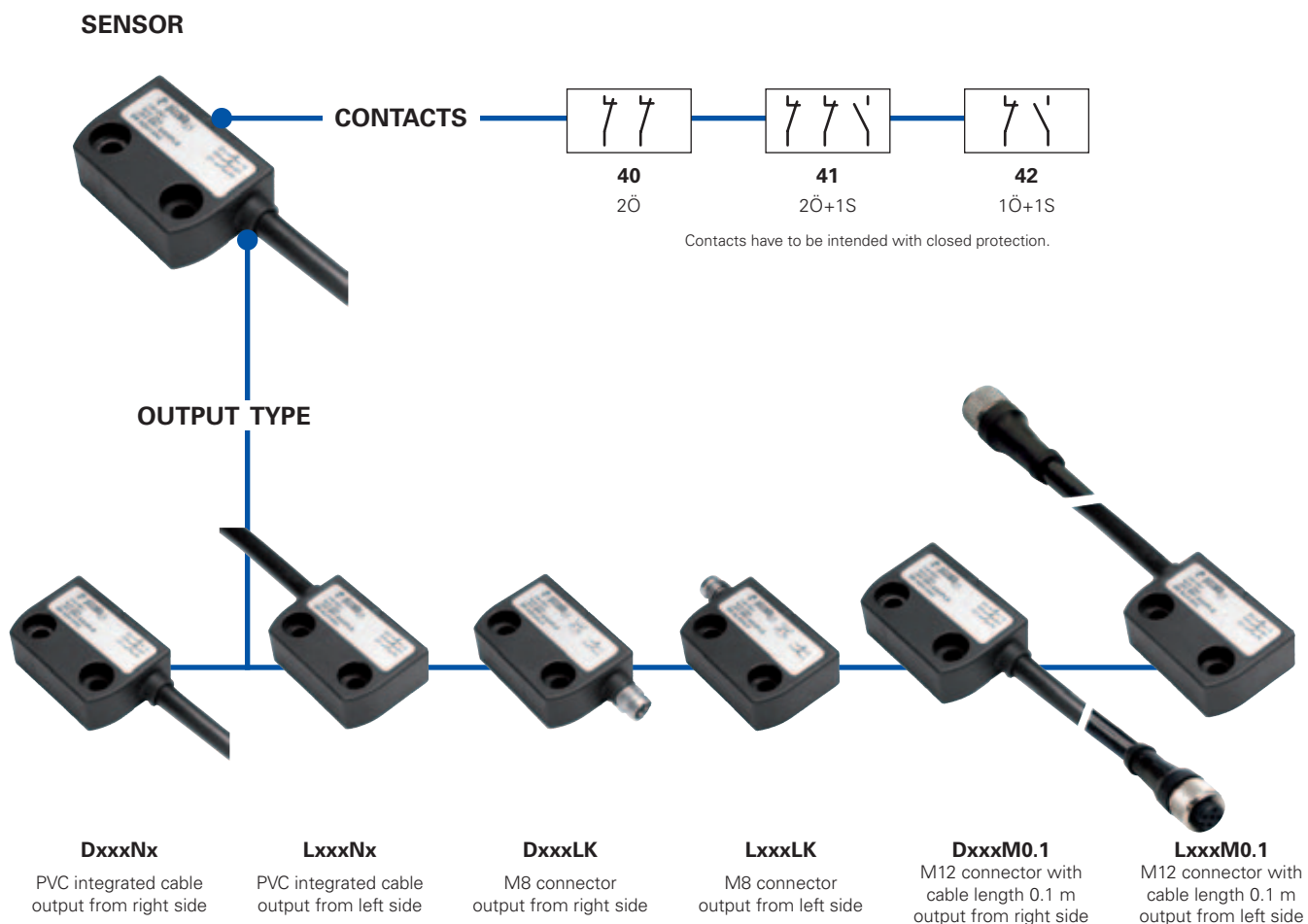

ACTUATOR



SMA01N

actuation distance 5 mm

● [[æ ä | { ~ + \

➔ åååå]] [ç] | æ] à [â ~ àç



NEW New features 2009

IP69K

Protection degree IP69K for SR series

- Protection degree IP69K according to standard DIN 40050 part 9
- Suitable for use in machineries subjected to intense washings, such as in the food or pharmaceutical industry

NEW New features 2009



Approval UL for SR series

Sensor with actuator code structure

SR AD40AN2-A01N

Sensor housing		Actuator	
SR	polymer housing	A01N	complete with SM A01N actuator, actuation distance 5 mm
Connection output direction		Type of cable or connector	
D	Output from right	N1	integrated PVC cable, length 1 m
L	Output from left	N2	integrated PVC cable, length 2 m
Contacts (with closed protection)	
40	2NC	N10	Integrated PVC cable, length 10 m
41	1NO+2NC	M0.1	M12 connector with cable length 0.1 m
42	1NO+1NC	LK	M8 connector (available with 40 and 42 contacts only)

Single sensor code structure

SR AD40AN2

Sensor housing		Type of cable or connector	
SR	polymer housing	N1	integrated PVC cable, length 1 m
Connection output direction		N2	integrated PVC cable, length 2 m
D	Output from right
L	Output from left	N10	Integrated PVC cable, length 10 m
Contacts (with closed protection)		M0.1	M12 connector with cable length 0.1 m
40	2NC	LK	M8 connector (available with 40 and 42 contacts only)
41	1NO+2NC		
42	1NO+1NC		

Actuator code structure

SM A01N

Actuator	
A01N	actuation distance 5 mm

- 1
- 1A
- 1B
- 2
- 2A
- 2B
- 2C
- 2D
- 2E
- 3
- 3A
- 3B
- 3C
- 4
- 4A
- 4B**
- 4C
- 4D
- 4E
- 4F
- 4G
- 4H
- 5
- 6

**Main data**

- Long life, no mechanical wear
- Stainless steel fixing plates
- Output contacts: 2NC, 1NO+2NC or 1NO+1NC
- Insensitive to dirt
- Protection degree IP67 and IP69K
- Coded actuator
- Polymer housing
- Versions with M8 or M12 connector

Markings and quality marks:

Approval UL:



E131787

In conformity with requirements requested by:

Low Voltage Directive 2006/95/EC
 Machinery Directive 2006/42/EC
 Electromagnetic Compatibility 2004/108/EC.

Technical data**Housing**

Made of glass-reinforced polymer, self-extinguishing, shock-proof thermoplastic resin. Version with integrated cable with 4 or 6 x 0.25 mm² wires length 2 m, other lengths on request.

Versions with M8 or M12 connector.

Protection degree:

IP67 according to EN 60529
 IP69K according to DIN 40050

Dimensions L x P x H:

36 x 26 x 13 mm

General data

Safety parameters:

see page 6/32

Ambient temperature:

-20°C ... +80°C

Vibrations holding:

10 gn (10...500 Hz) according to IEC 60068-2-6

Shock holding:

30 gn (11 ms) according to IEC 60068-2-27

Pollution degree

3

Max screw driving torque:

0,8 ... 2 Nm

In conformity with standards:

IEC 60947-1, EN 60947-1, IEC 60947-5-1, EN 60947-5-1, EN 60947-5-2, EN 60947-5-3 (in connection with safety module), EN 1088, EN ISO 14119, EN ISO 12100-1, EN ISO 12100-2, EN ISO 13849-1, EN ISO 13849-2, IEC 60204-1, EN 60204-1, IEC 60529, EN 60529.

Approvals:

UL 508

Actuating data

Assured operating distance S_{ao}

5 mm with actuator A01N

Assured release distance S_{ar}

15 mm with actuator A01N

Repeat accuracy

≤ 10%

Frequency of operating cycles

150 Hz

Distance between two sensors

Min. 50 mm

Electrical data

Rated insulation voltage U_i :

120 Vac (with cable)

60 Vac / 75 Vdc (with M8 connector)

120 Vac (with 4 poles M12 connector)

30 Vac / 36 Vdc (with 8 poles M12 connector)

Thermal current I_{th} :

0,25 A

Max switching load

6 W (resistive load)

Rated operational voltage (U_e):

24 VAC/DC

Rated operational current (I_e):

0.25 A (resistive load)

Protection fuse:

0.25 A type F

Electrical endurance:

1 million operations cycles

Connection with safety modules with personnel protection function:

Connection with safety modules CS AR-08; CS AR-05; CS AR-06; CS AT-0; CS AT-1; CS AT-2

The sensor connected with the safety module can be classified as device for control circuit up to PDF-M (EN 60947-5-3). The system can be used in safety circuits up to category 4 according to EN 954-1.

Data type approved by UL

Utilization categories: 24 Vdc, 0,25 A (resistive load)

Data of the housing type 1, 4X "indoor use only", 12

Accessory of series CS.

In conformity with standard: UL 508

Please contact our technical service for the list of approved products.



Introduction

Coded magnetic sensors are devices studied to monitor protections and guards that, when linked to a safety module, can create a system with safety category up to SIL 3 according to EN 62061, up to PLe according to EN ISO 13849-1 and up to category 4 according to EN 954-1. These products are composed by a magnetic field monitoring sensor, which is connected to the machine structure; and by a coded magnetic actuator, which has to be connected to the mobile guards. When sensor and actuator are neared (closed guard), the sensor recognizes the actuator and provides to actuate electric contacts. The sensor is manufactured to be activated only by the correct coded actuator and not through a common magnet.

Insensitivity to dirt

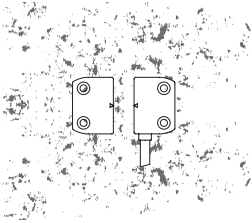

Magnetic sensors are totally sealed and maintain unchanged their safety characteristics also where dirt and dust are present (not ferromagnetic material).

This characteristic, joined with the shape without recesses, make them especially proper to the use in the agro-industrial sector.

Wide actuation zone

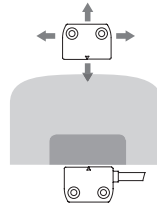

Because of their intrinsic characteristics, magnetic sensors have a wide actuation zone, which make them appreciated in the use of inaccurate protections or for protection that can change their mechanic characteristics through the time.

In this type of sensors actuation distances may change according to the actuator displacement direction from the sensor.

Alignment marks

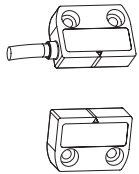

Sensors and magnets are provided with marks on the housing, as reference for operating distances. For a correct working, install sensors with facing marks (see figure).

Actuation from many directions

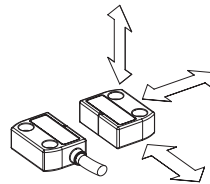

Pizzato Elettrica magnetic sensors have been designed in order to be activated by the related actuator from many directions. In this way, the customer has the max flexibility about the placing of the devices along the protections perimeters.

Coded magnetic sensors used for safety applications

A coded magnetic sensor alone can not be used for safety functions because its working principles are not considered safe by the standards (as are, for example, the positive opening on mechanical switches). For this reason a coded magnetic sensor, in order to be used in safety applications, has to be compulsory connected to a proper safety module which monitors its right working.

Complete safety system

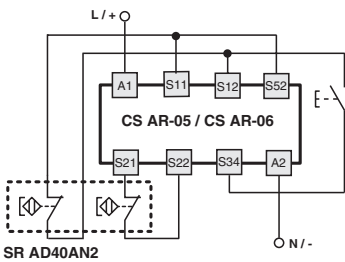

These magnetic sensors have been checked and tested for working with proper Pizzato Elettrica safety modules.

Using completed and tested solutions, the customer has the certainty to have no electric incompatibility between sensor and safety module, and has a higher reliability guarantee.

Connection of sensors and switches in series

Pizzato Elettrica magnetic sensors could be connected in series with the only limitation that the overall resistance, gave by sensors and the related wiring, has to be not higher than the admitted max value of the module, which is typically 50 ohm (see module features). It is a very high value that, with normal wiring, it allows the use of dozens of sensors without problems.

It is also possible to make mixed circuit solutions connecting in series magnetic sensor to safety switches, with the only limitation of the above mentioned max electric resistance. We remind you that the connection in series of two or more safety sensor, makes the sensors-module system of category 3, according to EN 954-1.

Sensors	Compatible safety modules	Safety module output contacts
SR A•40A•• SR A•41A••	CS AR-05•••••	3NO+1NC
	CS AR-06•••••	3NO+1NC
	CS AR-08•••••	2NO
	CS AT-0•••••	2NO+1NO (ist. cont.)+2NO (del. cont.)
	CS AT-1•••••	3NO (ist. cont.)+2NO (del. cont.)
	CS AT-2•••••	2NO (ist. cont.)+1NO (del. cont.)

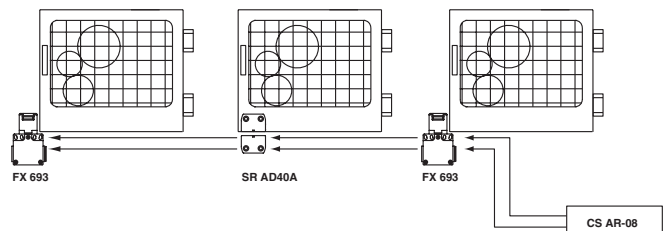

For safety modules technical data see page 4/123

Wiring with safety modules

Wiring with safety modules CS AR-05 or CS AR-06

Input configuration with manual start (CS AR-05) and monitored start (CS AR-06)
2 channels

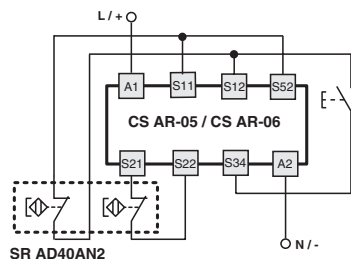

Wiring with safety module CS AR-08 or CS AT

Input configuration with manual start
2 channels

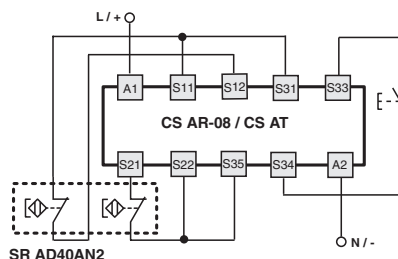

For safety modules technical data see page 4/123

Internal connections

Contacts imply closed protection

With cable (2NC)

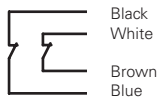

Black
White

Brown
Blue

With cable (1NC+1NO)

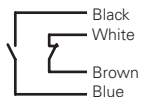

Black
White

Brown
Blue

With cable (2NC+1NO)



Green
Brown
Grey

Pink
White
Yellow

With M8 connector (2NC)



1 2
3 4

With M8 connector (1NC+1NO)



1 2
3 4

With M12 connector (2NC+1NO)



3 4
5 6
7 8

With M12 connector (2NC)



1 2
3 4

With M12 connector (1NC+1NO)



1 2
3 4

Intervention distance SR AD.....-B01F

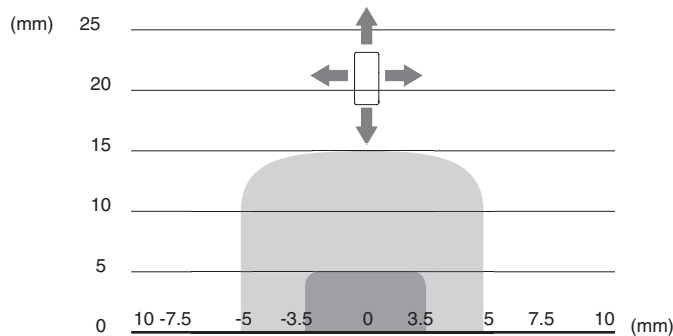
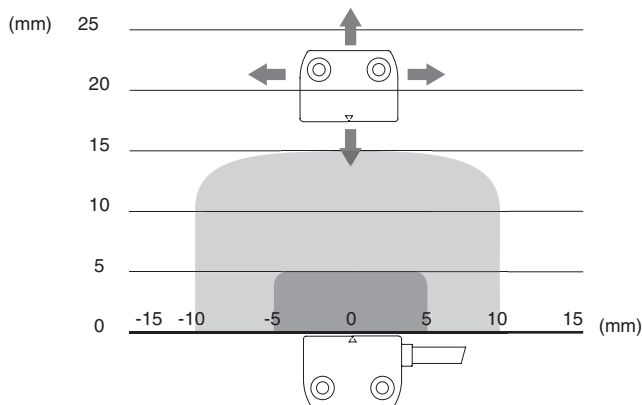

Intervention distance SR AD.....-B02F

Legend:

- Assured operating distance Sao
- Assured release distance Sar

Note: The drawing of the activation areas is indicative.



Dimensional drawings

Sensor with cable, length 2 m		Sensor with cable, length 2 m	
SR AD40AN2	2NC	SR AL40AN2	2NC
SR AD41AN2	1NO+2NC	SR AL41AN2	1NO+2NC
SR AD42AN2	1NO+1NC	SR AL42AN2	1NO+1NC

Coded actuator	
SM A01N	1NO+1NC

Sensor with M8 connector		Sensor with M8 connector		M12 connector with cable length 0.1 m output from right side		M12 connector with cable length 0.1 m output from left side	
SR AD40ALK	2NC	SR AL40ALK	2NC	SR AD40AM0.1	2NC	SR AL40AM0.1	2NC
SR AD41ALK	1NO+2NC	SR AL41ALK	1NO+2NC	SR AD41AM0.1	1NO+2NC	SR AL41AM0.1	1NO+2NC
SR AD42ALK	1NO+1NC	SR AL42ALK	1NO+1NC	SR AD42AM0.1	1NO+1NC	SR AL42AM0.1	1NO+1NC

Utilization limits

- The installation must be performed by qualified staff only.
- Before installation and at regular interval, check the right contacts switching and the system operation of the sensor and the associated safety module.
- Do not use a hammer for adjustment.
- Do not use the sensor as a mechanical stop.
- Observe the assured operating and release distances.
- It is advisable to make adjustment observing the diagram reported in the switching distances section.
- Do not install the sensor and the actuator on strong magnetic field.
- Keep away from iron filing.

Shock, vibrations and wear:

- Do avoid impact with the sensor. Excessive shock and vibrations could not guarantee the right working of the sensor.
- The actuator must not strike sensor.
- In case of damages or wear is necessary to change the whole device, included the actuator.

Warning during the wiring:

- Keep load under the value indicated in the electrical data.
- When the sensor contacts are used without the respective safety module, connect in series to each contact the protection fuse indicated in the electrical data.
- Turn off the power supply before check the switch connection contacts, also during the wiring.

Multiple systems sensor-actuator assembly

The minimum mounting gap between sensor-actuator systems must be at least 50 mm.

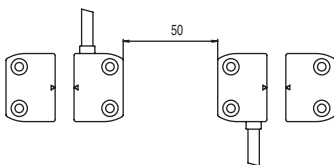

Installation on ferromagnetic material

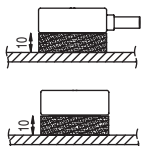

- If possible do not mount the sensor and the actuator on ferromagnetic materials.
- In order to avoid switching distances reductions, use a non-magnetic shim minimum thickness ≥ 10 mm.

Accessories See page 5/1

Items with code on the green background are available in stock

All measures in the drawings are in mm

1
1A
1B
2
2A
2B
2C
2D
2E
3
3A
3B
3C
4
4A
4B
4C
4D
4E
4F
4G
4H
5
6