



**Bimanual control device according to EN 574 type III C or safety module with synchronism control**

#### Main functions

- For safety applications up to SIL 3 / PL e
- Input circuit with 2 channels for bimanual control device or safety gate
- Connection of the input channels to opposite potentials
- Small 22,5 mm housing
- 3 NO safety contacts, 1 NC auxiliary contact
- Supply voltages: 24 Vac/dc, 120 Vac, 230 Vac

#### Utilization categories

Alternate current: AC15 (50...60 Hz)

U<sub>e</sub> (V) 230

I<sub>e</sub> (A) 3

Direct current: DC13 (6 operations/minute)

U<sub>e</sub> (V) 24

I<sub>e</sub> (A) 4

#### Markings, quality marks and certificates:



Approval UL:

E131787

Certificate CE type n°:

IMQ BP 210 DM

#### Complying with the requirements requested by:

Low Voltage Directive 2006/95/EC,

Machinery Directive 2006/42/EC,

Electromagnetic Compatibility 2004/108/EC

#### Technical data

##### Housing

Made of polyamide PA 6.6 self-extinguishing, class V0 (UL94)

Protection degree:

IP40 (housing), IP20 (terminals)

Dimensions:

see page 5/81, shape A

##### General data

SIL level (SIL CL):

up to SIL 3 according to EN IEC 62061

Performance Level (PL):

up to PL e according to EN ISO 13849-1

Safety category:

up to category 4 according to EN 954-1

Device type for bimanual control:

EN 574: type III C

Safety parameters:

see page 7/32

Ambient temperature:

-25°C...+55°C

Mechanical endurance:

>10 millions of operations

Electrical endurance:

>100.000 operations

Pollution degree:

outside 3, inside 2

Rated impulse with stand voltage (U<sub>imp</sub>):

4 kV

Rated insulation voltage (U<sub>i</sub>):

250 V

Over-voltage category:

II

Weight:

0,3 Kg

##### Power supply

Rated operating voltage (Un):

24 Vac/dc; 50...60 Hz

120 Vac; 50...60 Hz

230 Vac; 50...60 Hz

Max residual ripple in DC:

10%

Supply voltage tolerance:

±15% of Un

Rated power consumption AC:

< 5 VA

Rated power consumption DC:

< 2 W

##### Control circuit

Protection against short circuits:

resistance PTC, I<sub>h</sub>=0,5 A

Operating time of PTC:

intervention > 100 ms, reset > 3 s

Max input resistance:

≤ 50 Ω

Current for each input:

30 mA

Operating time t<sub>A</sub>:

50 ms

Releasing time t<sub>R1</sub>:

20 ms

Releasing time in absence of power supply t<sub>R</sub>:

70 ms

Time range for synchronized control t<sub>S</sub>:

< 0,5 s

##### In conformity with standards:

IEC 60947-1, EN 60947-5-1, IEC 60204-1, EN 60204-1, EN ISO 13849-1, EN 999, EN 1037, EN ISO 12100-1, EN ISO 12100-2, EN ISO 13850, IEC 529, EN 60529, EN 61000-6-2, EN 61000-6-3, EN 62326-1, EN 60664-1, EN 60947-5-1, EN 62061, EN 13849-1, UL 508, CSA C22.2 n° 14-95

##### Output circuit

Output contacts:

3 NO safety contacts,

1 NC auxiliary contact

forced guided contacts

silver alloy, gold plated

230/240 Vac; 300 Vdc

Contacts type:

6 A

Contacts material:

6 A

Max switching voltage:

64 A<sup>2</sup>

Max switching current per contact:

10 mA

Conventional free air thermal current I<sub>th</sub>:

≤ 100 mΩ

Min. current:

6 A, F type

Contacts resistance:

6 A, F type

Contact protection fuse:

6 A, F type

The number and the load capacity of output contacts can be increased by using expansion modules or contactors See page 5/49 - 5/58 and 5/79

#### Code structure

## CS DM-01V024

Kind of connection	
<b>V</b>	screw terminals
<b>M</b>	connector with screw terminals
<b>X</b>	connector with spring terminals

Supply voltage		
<b>024</b>	24 Vac/dc	±15%
<b>120</b>	120 Vac	±15%
<b>230</b>	230 Vac	±15%

#### Items available on stock

CS DM-01V024

#### Data type approved by UL

Rated operating voltage (Un): 24 Vac/dc; 50...60 Hz  
120 Vac; 50...60 Hz  
230 Vac; 50...60 Hz

Rated power consumption AC: < 5 VA

Rated power consumption DC: < 2 W

Max switching voltage: 230 Vac

Max switching current per contact: 6 A

Utilization category: C300

Notes:

- Use 60° or 75 °C copper (Cu) conductor and wire size No. 30-12 AWG.

- Terminal tightening torque of 5-7 Lb In.

- Only for 24 Vac/dc version, supply from remote class 2 source or limited voltage and limited energy.



# Safety module CS DM-01

## Terminals layout

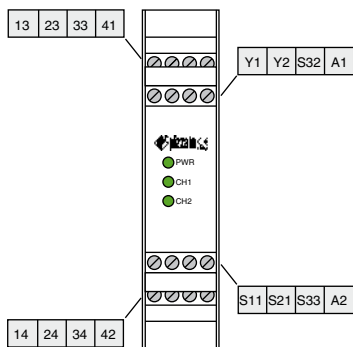

## Operations diagram

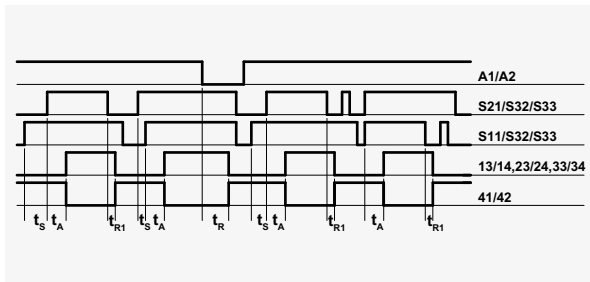

Legend:  
 $t_s$ : Time range for synchronized control  
 $t_a$ : Operating time  
 $t_r$ : Releasing time  
 $t_{r1}$ : Releasing time in absence of power supply

## Internal wiring diagram

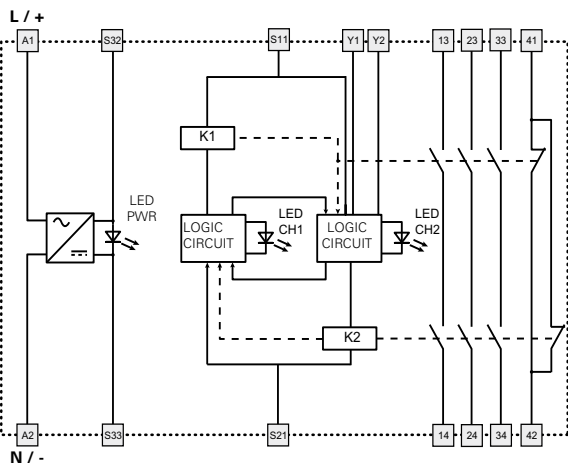

## Inputs configuration

Bimanual control device type III C according to EN 574

Safety gate monitoring with automatic start wiring and simultaneity between channels < 0,5 s (safety category 4)

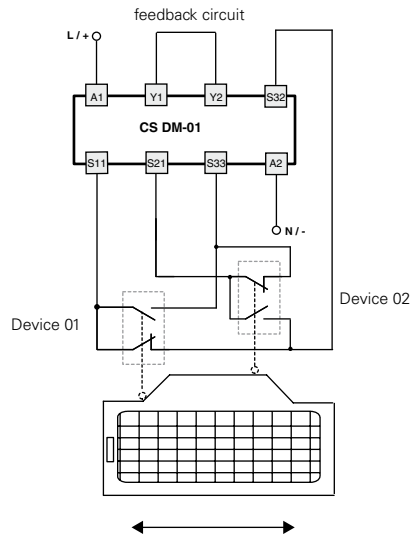
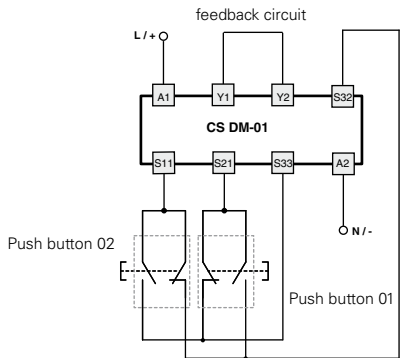

The diagram does not show the exact position of clamps in the product



**Bimanual control device according to EN 574 type III C or safety module with synchronism control**

#### Main functions

- For safety applications up to SIL 3 / PL e
- Input circuit with 2 channels for bimanual control device or safety gate
- Connection of the input channels to opposite potentials
- Small 22,5 mm housing
- 2 NO safety contacts,
- Supply voltages:  
24 Vac/dc, 120 Vac, 230 Vac

#### Utilization categories

Alternate current: AC15 (50...60 Hz)

U<sub>e</sub> (V) 230

I<sub>e</sub> (A) 3

Direct current: DC13 (6 operations/minute)

U<sub>e</sub> (V) 24

I<sub>e</sub> (A) 4

#### Markings, quality marks and certificates:



Approval UL: E131787

Certificate CE type n°: IMQ BP 210 DM

#### Complying with the requirements requested by:

Low Voltage Directive 2006/95/EC,

Machinery Directive 2006/42/EC,

Electromagnetic Compatibility 2004/108/EC

#### Technical data

##### Housing

Made of polyamide PA 6.6 self-extinguishing, class V0 (UL94)

Protection degree:

IP40 (housing), IP20 (terminals)

Dimensions:

see page 5/81, shape A

##### General data

SIL level (SIL CL):

up to SIL 3 according to EN IEC 62061

Performance Level (PL):

up to PL e according to EN ISO 13849-1

Safety category:

up to category 4 according to EN 954-1

Device type for bimanual control:

EN 574: type III C

Safety parameters:

see page 7/32

Ambient temperature:

-25°C...+55°C

Mechanical endurance:

>10 millions of operations

Electrical endurance:

>100.000 operations

Pollution degree:

outside 3, inside 2

Rated impulse with stand voltage (U<sub>imp</sub>):

4 kV

Rated insulation voltage (U<sub>i</sub>):

250 V

Over-voltage category:

II

Weight:

0,3 Kg

##### Power supply

Rated operating voltage (U<sub>n</sub>):

24 Vac/dc; 50...60 Hz

120 Vac; 50...60 Hz

230 Vac; 50...60 Hz

Max residual ripple in DC:

10%

Supply voltage tolerance:

±15% of U<sub>n</sub>

Rated power consumption AC:

< 5 VA

Rated power consumption DC:

< 2 W

##### Control circuit

Protection against short circuits:

resistance PTC, I<sub>h</sub>=0,5 A

Operating time of PTC:

intervention > 100 ms, reset > 3 s

Max input resistance:

≤ 50 Ω

Current for each input:

30 mA

Operating time t<sub>A</sub>:

30 ms

Releasing time t<sub>R1</sub>:

25 ms

Releasing time in absence of power supply t<sub>R</sub>:

90 ms

Time range for synchronized control t<sub>S</sub>:

< 0,5 s

#### In conformity with standards:

IEC 60947-1, EN 60947-5-1, IEC 60204-1, EN 60204-1, EN ISO 13849-1, EN 999, EN 1037, EN ISO 12100-1, EN ISO 12100-2, EN ISO 13850, IEC 529, EN 60529, EN 61000-6-2, EN 61000-6-3, EN 62326-1, EN 60664-1, EN 60947-5-1, EN 62061, EN 13849-1, UL 508, CSA C22.2 n° 14-95

##### Output circuit

Output contacts:

2 NO safety contacts,

Contacts type:

forced guided contacts

Contacts material:

silver alloy, gold plated

Max switching voltage:

230/240 Vac; 300 Vdc

Max switching current per contact:

6 A

Conventional free air thermal current I<sub>th</sub>:

6 A

Max currents sum Σ I<sub>th</sub><sup>2</sup>:

36 A<sup>2</sup>

Min. current:

10 mA

Contacts resistance:

≤ 100 mΩ

Contact protection fuse:

6 A, F type

The number and the load capacity of output contacts can be increased by using expansion modules or contactors See page 5/49 - 5/58 and 5/79

#### Code structure

## CS DM-02V024

Kind of connection	Supply voltage
<b>V</b> screw terminals	<b>024</b> 24 Vac/dc ±15%
<b>M</b> connector with screw terminals	<b>120</b> 120 Vac ±15%
<b>X</b> connector with spring terminals	<b>230</b> 230 Vac ±15%

#### Data type approved by UL

Rated operating voltage (U <sub>n</sub> ):	24 Vac/dc; 50...60 Hz 120 Vac; 50...60 Hz 230 Vac; 50...60 Hz
Rated power consumption AC:	< 5 VA
Rated power consumption DC:	< 2 W
Max switching voltage:	230 Vac
Max switching current per contact:	6 A
Utilization category	C300

Notes:

- Use 60° or 75 °C copper (Cu) conductor and wire size No. 30-12 AWG.

- Terminal tightening torque of 5-7 Lb In.

- Only for 24 Vac/dc version, supply from remote class 2 source or limited voltage and limited energy.



# Safety module CS DM-02

## Terminals layout

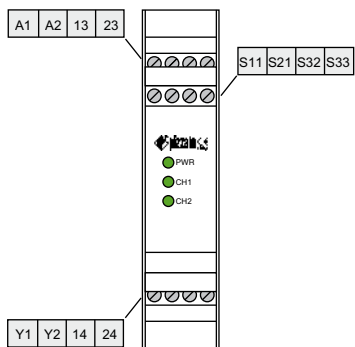

## Operations diagram

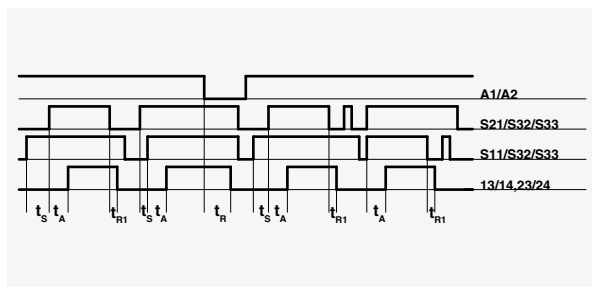

Legend:  
 $t_s$ : Time range for synchronized control  
 $t_A$ : Operating time  
 $t_{R1}$ : Releasing time  
 $t_R$ : Releasing time in absence of power supply

## Internal wiring diagram

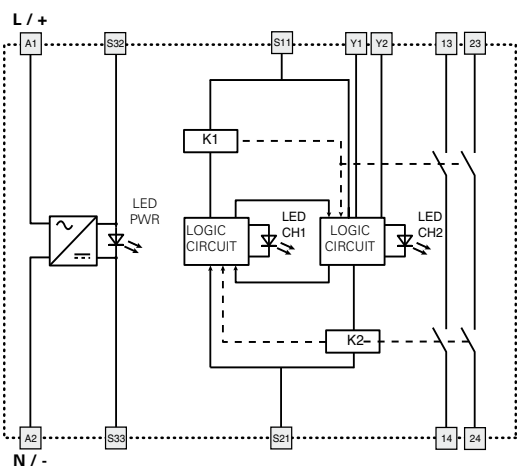

## Inputs configuration

Bimanual control device type III C according to EN 574

Safety gate monitoring with automatic start wiring and simultaneity between channels < 0,5 s (safety category 4)

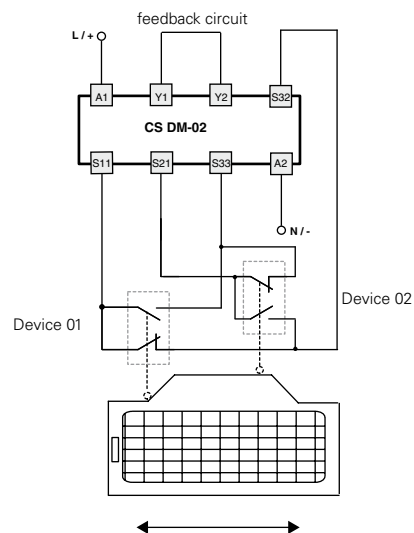
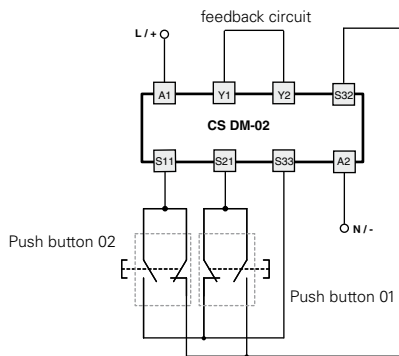

The diagram does not show the exact position of clamps in the product