

Module, with delayed contacts at the opening of the input channels, for emergency stop, gate monitoring, solid state output devices and magnetic safety sensor

Main functions

- For safety applications up to SIL 3 / PL e
- Single or dual channel input circuit
- Choice between automatic start, manual start or monitored start
- Connection of the input channels to opposite potentials
- Connectible to solid-state output circuits (for example optical barriers), to electromechanical contacts or to magnetic safety sensor
- 45 mm housing
- 2 NO safety instantaneous contacts, 1 NC auxiliary instantaneous contact, 2 NO safety delayed contacts.
- Supply voltages: 24 Vac/dc, 120 Vac, 230 Vac

Utilization categories

Alternate current: AC15 (50...60 Hz)
 Ue (V) 230
 Ie (A) 3
 Direct current: DC13 (6 operations/minute)
 Ue (V) 24
 Ie (A) 4

Markings, quality marks and certificates:



Approval UL: E131787

Complying with the requirements requested by:

Low Voltage Directive 2006/95/EC,
 Machinery Directive 2006/42/EC,
 Electromagnetic Compatibility 2004/108/EC

Technical data

Housing

Made of polyamide PA 6.6 self-extinguishing, class V0 (UL94)
 Protection degree: IP40 (housing), IP20 (terminals)
 Dimensions: see page 5/82, shape C

General data

SIL level (SIL CL): up to SIL 3 according to EN IEC 62061
 Performance Level (PL): up to PL e according to EN ISO 13849-1
 Safety category: up to category 4 (instantaneous contacts)
 category 3 (delayed contacts)
 according to EN 954-1

Safety parameters:

Ambient temperature: -25°C...+55°C
 Mechanical endurance: > 10 millions of operations
 Electrical endurance: > 100.000 operations
 Pollution degree: outside 3, inside 2
 Rated impulse with stand voltage (Uimp): 4 kV
 Rated insulation voltage (Ui): 250 V
 Over-voltage category: II
 Weight: 0,5 Kg

Power supply

Rated operating voltage (Un): 24 Vac/dc; 50...60 Hz
 120 Vac; 50...60 Hz
 230 Vac; 50...60 Hz
 Max residual ripple in DC: 10%
 Supply voltage tolerance: ±15% of Un
 Rated power consumption AC: < 10 VA
 Rated power consumption DC: < 5 W

Control circuit

Protection against short circuits: resistance PTC, I_h=0,5 A
 Operating time of PTC: intervention > 100 ms, reset > 3 s
 Max input resistance: ≤ 50 Ω
 Current for each input: 30 mA
 Min. period of start impulse t_{MIN}: 200 ms
 Operating time t_A: 150 ms
 Releasing time t_{R1}: 20 ms
 Releasing time in absence of power supply t_R: 150 ms
 Releasing time delayed contacts t_{R2}: see "CODE STRUCTURE"
 Simultaneity time t_C: infinite

In conformity with standards:

IEC 60947-1, EN 60947-5-1, IEC 60204-1, EN 60204-1, EN ISO 13849-1, EN 999, EN 1037, EN ISO 12100-1, EN ISO 12100-2, EN ISO 13850, IEC 529, EN 60529, EN 61000-6-2, EN 61000-6-3, EN 62326-1, EN 60664-1, EN 60947-5-1, EN 62061, EN 13849-1, UL 508, CSA C22.2 n° 14-95

Output circuit

Output contacts: 2 NO safety instantaneous contacts,
 1 NC auxiliary instantaneous contact,
 2 NO safety delayed contacts.
 Contacts type: forced guided contacts
 Contacts material: silver alloy, gold plated
 Max switching voltage: 230/240 Vac; 300 Vdc
 Max switching current per contact: 6 A
 Conventional free air thermal current I_{th}: 6 A
 Max currents sum Σ I_{th}²: 72 (instantaneous cont.), 36 (delayed cont.) A²
 Min. current: 10 mA
 Contacts resistance: ≤ 100 mΩ
 Contact protection fuse: 6 A, F type

The number and the load capacity of output contacts can be increased by using expansion modules or contactors See page 5/49 - 5/58 and 5/79

Code structure

CS AT-00V024-TF1

Releasing time delayed contacts (t_{R2})

0	Fixed time (see TF)
1	from 0,3 to 3 s, step 0,3 s
2	from 1 to 10 s, step 1 s
3	from 3 to 30 s, step 3 s
4	from 30 to 300 s, step 30 s

Releasing time delayed contacts (t_{R2})

TF0.5	fixed 0,5 s
TF1	fixed 1 s
TF3	fixed 3 s
...

Supply voltage

024	24 Vac/dc	±15%
120	120 Vac	±15%
230	230 Vac	±15%

Kind of connection	
V	screw terminals
M	connector with screw terminals
X	connector with spring terminals

Data type approved by UL

Rated operating voltage (Un): 24 Vac/dc; 50...60 Hz
 120 Vac; 50...60 Hz
 230 Vac; 50...60 Hz
 Rated power consumption AC: < 10 VA
 Rated power consumption DC: < 5 W
 Max switching voltage: 230 Vac
 Max switching current per contact: 6 A
 Utilization category: C300

Notes:
 - Use 60° or 75 °C copper (Cu) conductor and wire size No. 30-12 AWG.
 - Terminal tightening torque of 5-7 Lb In.
 - Only for 24 Vac/dc version, supply from remote class 2 source or limited voltage and limited energy.
 - Surrounding air of 55 °C.



Safety module CS AT-0

Terminals layout

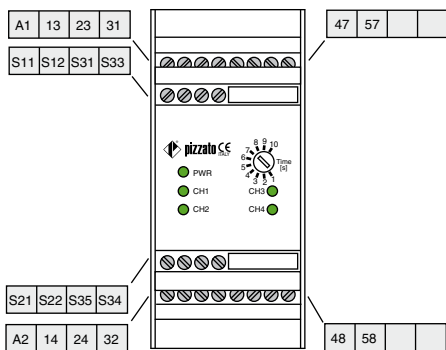

Internal wiring diagram

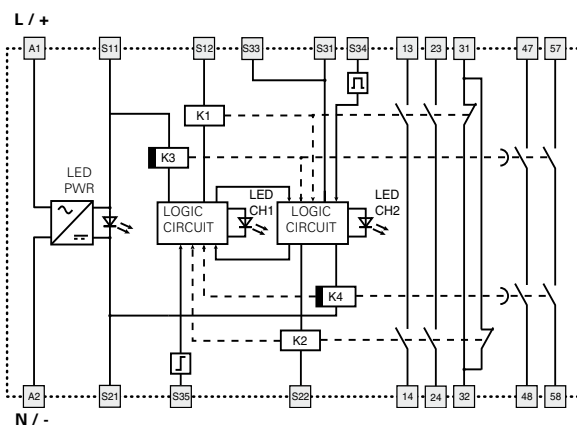

Inputs configuration

Solid-state output circuits (for example optical barriers)

Input configuration with manual start

1 channel

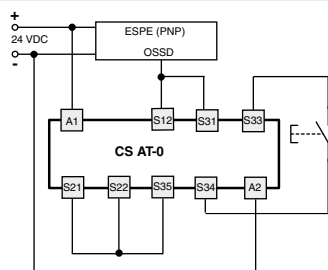

2 channels

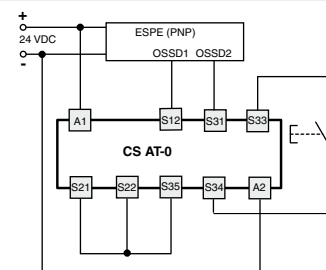

Emergency stop

Input configuration with manual start

1 channel

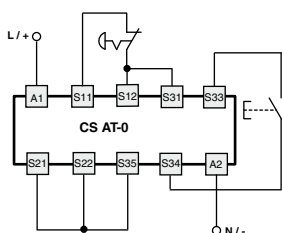

2 channels

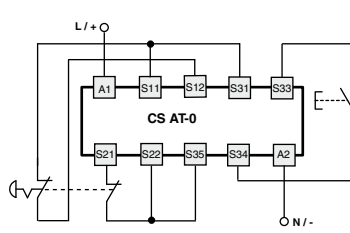

Operation diagrams

Configuration with automatic start

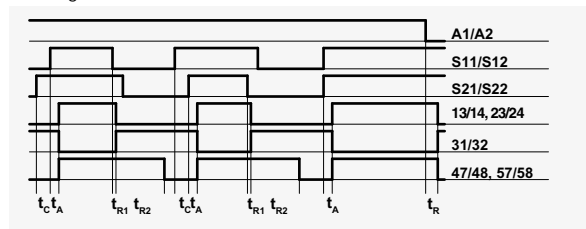

Configuration with monitored start

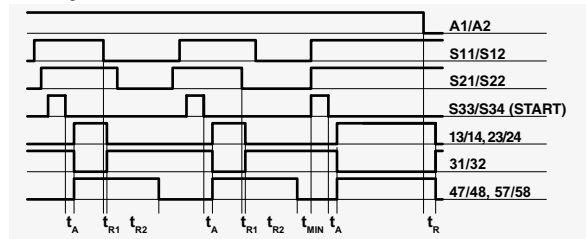

Configuration with manual start

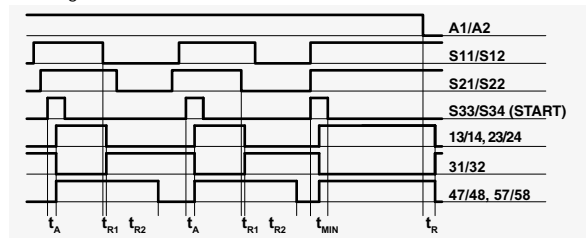

Legend:

- t_{MIN} : Min. period of start impulse
- t_c : Simultaneity time
- t_A : Operating time
- t_{r1} : Releasing time
- t_r : Releasing time in absence of power supply
- t_{r2} : Adjustable releasing time delayed contacts (see "Code structure")

Note:

The configurations with one channel are obtained taking into consideration only the S11/S12 input. In this case it is necessary to consider the t_{r1} and t_{r2} time referred to S11/S12 input, the t_r time referred to the supply, the t_A time referred to S11/S12 input and to the start, and the t_{MIN} time referred to the start.

Automatic start

As regards the indicated diagrams, in order to activate the module with the automatic start, it is necessary to short the start button between S33 and S34 terminals.

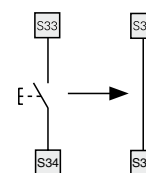

Monitored start

As regards the indicated diagrams, in order to activate the module with the monitored start, it is necessary to remove the connection between S22 and S35 terminals.

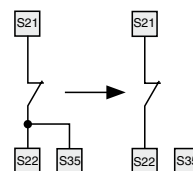

Gate monitoring and safety magnetic sensors

The safety module can control both emergency stop circuits, gate monitoring circuits or safety magnetic sensors. Replace the emergency stop contacts with switches contacts or with the sensors contacts. The sensors can only be used in the 2-channel configuration.

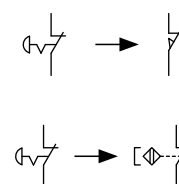

Application example See page 5/79



Module, with delayed contacts at the opening of the input channels, for emergency stop, gate monitoring, solid state output devices and magnetic safety sensor

Main functions

- For safety applications up to SIL 3 / PL e
- Single or dual channel input circuit
- Choice between automatic start, manual start or monitored start
- Connection of the input channels to opposite potentials
- Connectible to Solid-state output circuits (for example optical barriers), to electromechanical contacts or to magnetic safety sensor
- 45 mm housing
- 3 NO safety instantaneous contacts, 2 NO safety delayed contacts.
- Supply voltages: 24 Vac/dc, 120 Vac, 230 Vac

Utilization categories

Alternate current: AC15 (50...60 Hz)

Ue (V) 230

Ie (A) 3

Direct current: DC13 (6 operations/minute)

Ue (V) 24

Ie (A) 4

Markings, quality marks and certificates:



Approval UL: E131787

Complying with the requirements requested by:

Low Voltage Directive 2006/95/EC,

Machinery Directive 2006/42/EC,

Electromagnetic Compatibility 2004/108/EC

Technical data

Housing

Made of polyamide PA 6.6 self-extinguishing, class V0 (UL94)

Protection degree:

IP40 (housing), IP20 (terminals)

Dimensions:

see page 5/82, shape C

General data

SIL level (SIL CL):

up to SIL 3 according to EN IEC 62061

Performance Level (PL):

up to PL e according to EN ISO 13849-1

Safety category:

up to category 4 (instantaneous contacts)

category 3 (delayed contacts)

according to EN 954-1

see page 7/32

Safety parameters:

Ambient temperature:

-25°C...+55°C

Mechanical endurance:

> 10 millions of operations

Electrical endurance:

> 100.000 operations

Pollution degree:

outside 3, inside 2

Rated impulse with stand voltage (Uimp):

4 kV

Rated insulation voltage (Ui):

250 V

Over-voltage category:

II

Weight:

0,5 Kg

Power supply

Rated operating voltage (Un):

24 Vac/dc; 50...60 Hz

120 Vac; 50...60 Hz

230 Vac; 50...60 Hz

Max residual ripple in DC:

10%

Supply voltage tolerance:

±15% of Un

Rated power consumption AC:

< 10 VA

Rated power consumption DC:

< 5 W

Control circuit

Protection against short circuits:

resistance PTC, I_h=0,5 A

Operating time of PTC:

intervention > 100 ms, reset > 3 s

Max input resistance:

≤ 50 Ω

Current for each input:

30 mA

Min. period of start impulse t_{MIN}:

200 ms

Operating time t_A:

150 ms

Releasing time t_{R1}:

20 ms

Releasing time in absence of power supply t_R:

150 ms

Releasing time delayed contacts t_{R2}:

see "CODE STRUCTURE"

Simultaneity time t_C:

infinite

In conformity with standards:

IEC 60947-1, EN 60947-5-1, IEC 60204-1, EN 60204-1, EN ISO 13849-1, EN 999, EN 1037, EN ISO 12100-1, EN ISO 12100-2, EN ISO 13850, IEC 529, EN 60529, EN 61000-6-2, EN 61000-6-3, EN 62326-1, EN 60664-1, EN 60947-5-1, EN 62061, EN 13849-1, UL 508, CSA C22.2 n° 14-95

Output circuit

Output contacts:

3 NO safety instantaneous contacts,

2 NO safety delayed contacts.

Contacts type:

forced guided contacts

Contacts material:

silver alloy, gold plated

Max switching voltage:

230/240 Vac; 300 Vdc

Max switching current per contact:

6 A

Conventional free air thermal current I_{th}:

6 A

Max currents sum Σ I_{th}²:

72 (instantaneous cont.), 36 (delayed cont.) A²

Min. current:

10 mA

Contacts resistance:

≤ 100 mΩ

Contact protection fuse:

6 A, F type

The number and the load capacity of output contacts can be increased by using expansion modules or contactors See page See page 5/49 - 5/58 and 5/79

Code structure

CS AT-10V024-TF1

Releasing time delayed contacts (t_{R2})

0 Fixed time (see TF)

1 from 0,3 to 3 s, step 0,3 s

2 from 1 to 10 s, step 1 s

3 from 3 to 30 s, step 3 s

4 from 30 to 300 s, step 30 s

Kind of connection

V screw terminals

M connector with screw terminals

X connector with spring terminals

Releasing time delayed contacts (t_{R2})

TF0.5 fixed 0,5 s

TF1 fixed 1 s

TF3 fixed 3 s

...

Supply voltage

024 24 Vac/dc ±15%

120 120 Vac ±15%

230 230 Vac ±15%

Data type approved by UL

Rated operating voltage (Un):

24 Vac/dc; 50...60 Hz

120 Vac; 50...60 Hz

230 Vac; 50...60 Hz

Rated power consumption AC:

< 10 VA

Rated power consumption DC:

< 5 W

Max switching voltage:

230 Vac

Max switching current per contact:

6 A

Utilization category

C300

Note:

- Use 60° or 75 °C copper (Cu) conductor and wire size No. 30-12 AWG.

- Terminal tightening torque of 5-7 Lb In.

- Only for 24 Vac/dc version, supply from remote class 2 source or limited voltage and limited energy.

- Surrounding air of 55 °C.



Safety module CS AT-1

Terminals layout

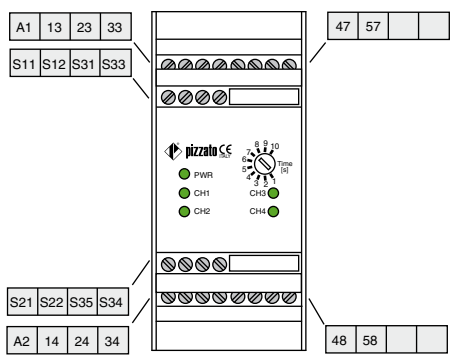

Internal wiring diagram

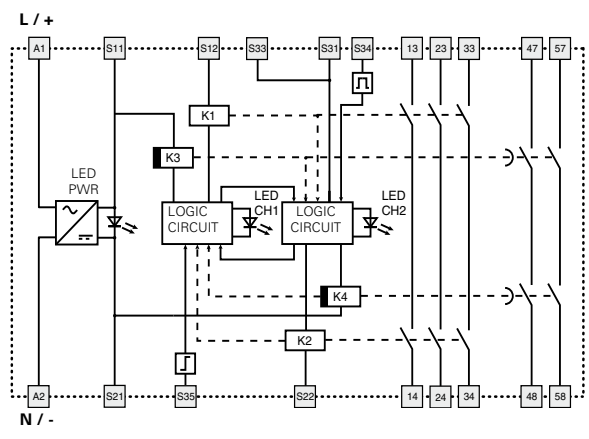

Operation diagrams

Configuration with automatic start

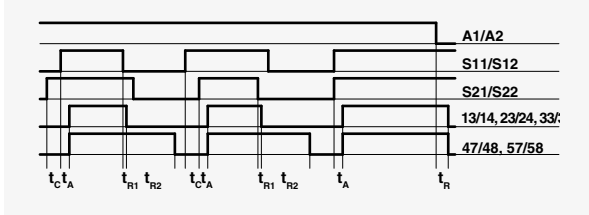

Configuration with monitored start

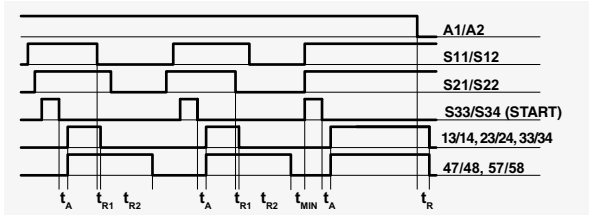

Configuration with manual start

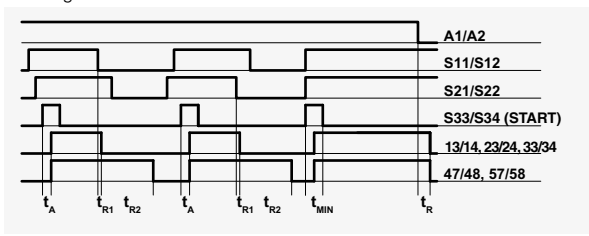

- Legend:
- t_{MIN} : Min. period of start impulse
 - t_c : Simultaneity time
 - t_o : Operating time
 - t_{R1} : Releasing time
 - t_{R2} : Releasing time in absence of power supply
 - t_{R2} : Adjustable releasing time delayed contacts (see "Code structure")

Note:
The configurations with one channel are obtained taking into consideration only the S11/S12 input. In this case it is necessary to consider the t_{R1} and t_{R2} time referred to S11/S12 input, the t_R time referred to the supply, the t_o time referred to S11/S12 input and to the start, and the t_{MIN} time referred to the start.

Inputs configuration

Solid-state output circuits (for example optical barriers)

Input configuration with manual start

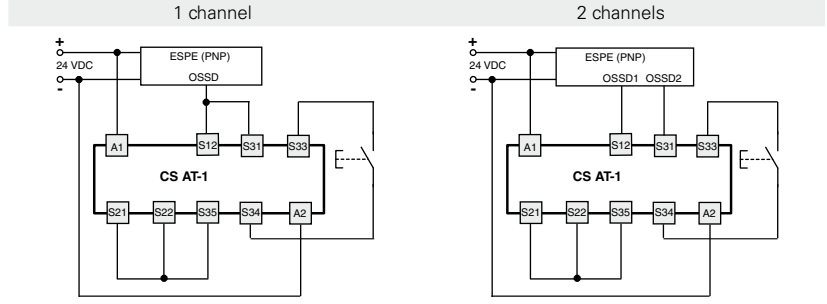

Emergency stop

Input configuration with manual start

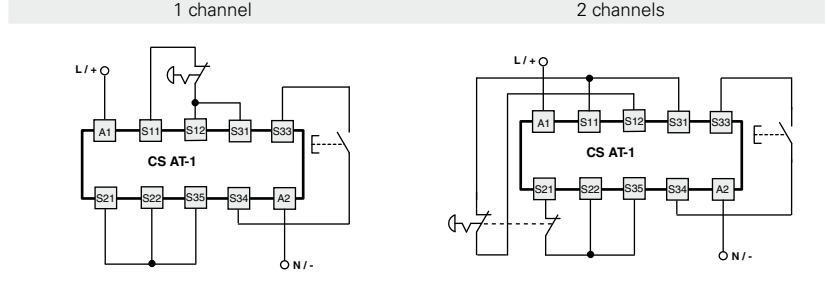

Automatic start

As regards the indicated diagrams, in order to activate the module with the automatic start, it is necessary to short the start button between S33 and S34 terminals.

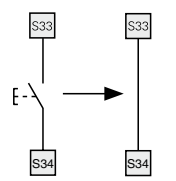

Monitored start

As regards the indicated diagrams, in order to activate the module with the monitored start, it is necessary to remove the connection between S22 and S35 terminals.

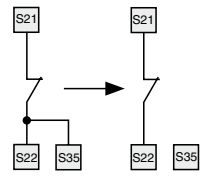

Gate monitoring and safety magnetic sensors.

The safety module can control both emergency stop circuits, gate monitoring circuits or safety magnetic sensors. Replace the emergency stop contacts with switches contacts or with the sensors contacts. The sensors can only be used in the 2-channel configuration.

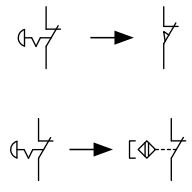

Application example See page 5/79



Module for emergency stop and gate monitoring and magnetic safety sensor with delayed contacts at the opening of the input channels

Main functions

- For safety applications up to SIL 3 / PL e
- Single or dual channel input circuit
- Choice between automatic start, manual start or monitored start
- Connectible to electromechanical contacts or to magnetic safety sensor
- 22,5 mm housing
- 2 NO safety instantaneous contacts, 1 NO safety delayed contact.
- Supply voltages: 24 Vac/dc

Utilization categories

Alternate current: AC15 (50...60 Hz)

U_e (V) 230

I_e (A) 3

Direct current: DC13 (6 operations/minute)

U_e (V) 24

I_e (A) 4

Markings, quality marks and certificates:



Approval UL: E131787

Complying with the requirements requested by:

Low Voltage Directive 2006/95/EC,

Machinery Directive 2006/42/EC,

Electromagnetic Compatibility 2004/108/EC

Technical data

Housing

Made of polyamide PA 6.6 self-extinguishing, class V0 (UL94)

Protection degree:

IP40 (housing), IP20 (terminals)

Dimensions:

see page 5/82, shape C

General data

SIL level (SIL CL):

up to SIL 3 according to EN IEC 62061

Performance Level (PL):

up to PL e according to EN ISO 13849-1

Safety category:

up to category 4 (instantaneous contacts)

category 3 (delayed contacts)

according to EN 954-1

see page 7/32

Safety parameters:

Ambient temperature:

-25°C...+55°C

Mechanical endurance:

>10 millions of operations

Electrical endurance:

>100.000 operations

Pollution degree:

outside 3, inside 2

Rated impulse with stand voltage (U_{imp}):

4 kV

Rated insulation voltage (U_i):

250 V

Over-voltage category:

II

Weight:

0,3 Kg

Power supply

Rated operating voltage (U_n):

24 Vac/dc; 50...60 Hz

Max residual ripple in DC:

10%

Supply voltage tolerance:

±15% of U_n

Rated power consumption AC:

< 10 VA

Rated power consumption DC:

< 5 W

Control circuit

Protection against short circuits:

resistance PTC, I_h=0,5 A

Operating time of PTC:

intervention > 100 ms, reset > 3 s

Max input resistance:

≤ 50 Ω

Current for each input:

30 mA

Min. period of start impulse t_{MIN}:

100 ms

Operating time t_A:

70 ms

Releasing time t_{R1}:

15 ms

Releasing time in absence of power supply t_R:

100 ms

Releasing time delayed contacts t_{R2}:

see "Code structure"

Simultaneity time t_c:

infinite

In conformity with standards:

IEC 60947-1, EN 60947-5-1, IEC 60204-1, EN 60204-1, EN ISO 13849-1, EN 999, EN 1037, EN ISO 12100-1, EN ISO 12100-2, EN ISO 13850, IEC 529, EN 60529, EN 61000-6-2, EN 61000-6-3, EN 62326-1, EN 60664-1, EN 60947-5-1, EN 62061, EN 13849-1, UL 508, CSA C22.2 n° 14-95

Output circuit

Output contacts:

2 NO safety instantaneous contacts,

1 NO safety delayed contact.

Contacts type:

forced guided contacts

Contacts material:

silver alloy, gold plated

Max switching voltage:

230/240 Vac; 300 Vdc

Max switching current per contact:

6 A

Conventional free air thermal current I_{th}:

6 A

Max currents sum Σ I_{th}²:

36 A²

Min. current:

10 mA

Contacts resistance:

≤ 100 mΩ

Contact protection fuse:

6 A, F type

The number and the load capacity of output contacts can be increased by using expansion modules or contactors See page 5/49 - 5/58 and 5/79

Code structure

CS AT-30V024-TF1

Releasing time delayed contacts (t_{R2})

0	Fixed time (see TF)
1	from 0,3 to 3 s, step 0,3 s
2	from 1 to 10 s, step 1 s
3	from 3 to 30 s, step 3 s
4	from 30 to 300 s, step 30 s

Releasing time delayed contacts (t_{R2})

TF0.5	fixed 0,5 s
TF1	fixed 1 s
TF3	fixed 3 s
...

Supply voltage

024	24 Vac/dc	±15%
------------	-----------	------

Kind of connection

V	screw terminals
M	connector with screw terminals
X	connector with spring terminals

Data type approved by UL

Rated operating voltage (U _n):	24 Vac/dc; 50...60 Hz
Rated power consumption AC:	< 10 VA
Rated power consumption DC:	< 5 W
Max switching voltage:	230 Vac
Max switching current per contact:	6 A
Utilization category	C300

Notes:

- Use 60° or 75 °C copper (Cu) conductor and wire size No. 30-12 AWG.

- Terminal tightening torque of 5-7 Lb In.

- Only for 24 Vac/dc version, supply from remote class 2 source or limited voltage and limited energy.

- Surrounding air of 55 °C.



Safety module CS AT-3

Terminals layout

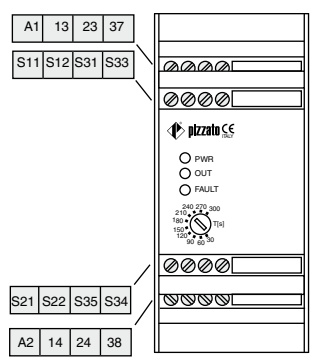

Internal wiring diagram

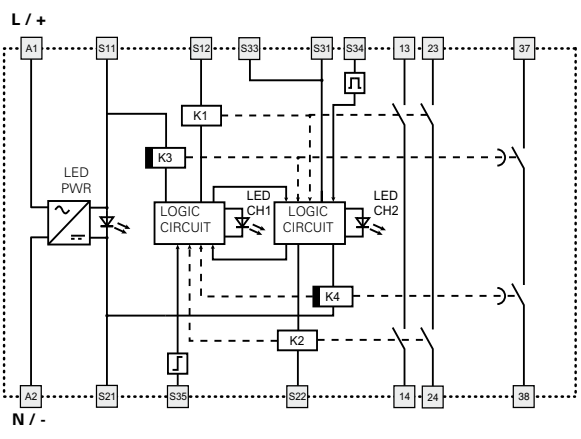

Operation diagrams

Configuration with automatic start

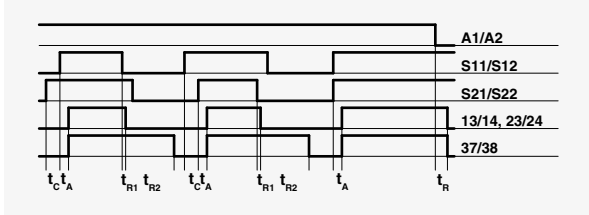

Configuration with monitored start

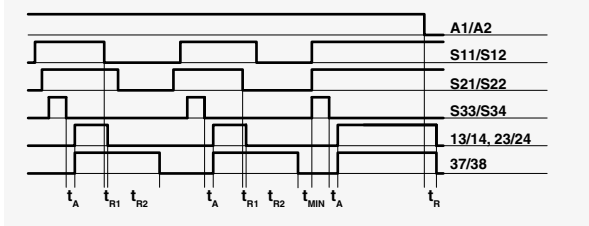

Configuration with manual start

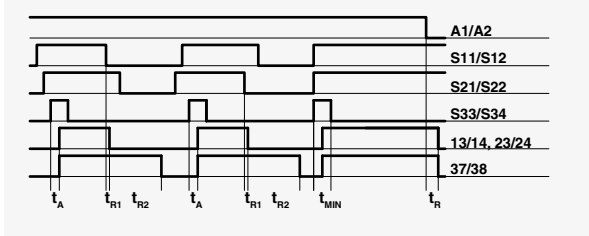

Legend:

- t_{MIN} : Min. period of start impulse
- t_c : Simultaneity time
- t_A : Operating time
- t_{R1} : Releasing time
- t_{R2} : Releasing time in absence of power supply
- t_{R2} : Adjustable releasing time delayed contacts (see "Code structure")

Note:

The configurations with one channel are obtained taking into consideration only the S11/S12 input. In this case it is necessary to consider the t_{R1} and t_{R2} times referred to S11/S12 input, the t_A time referred to the supply, the t_c time referred to S11/S12 input and to the start, and the t_{MIN} time referred to the start.

Inputs configuration

Emergency stop	
Input configuration with manual start	
1 channel	2 channels

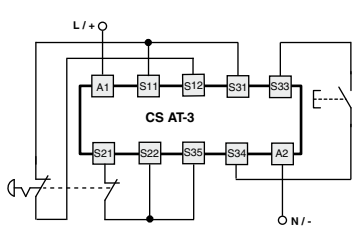
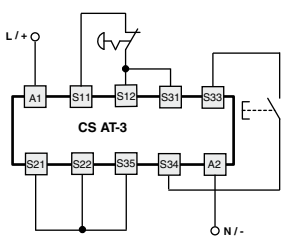

The diagram does not show the exact position of clamps in the product

Automatic start

As regards the indicated diagrams, in order to activate the module with the automatic start, it is necessary to short the start button between S33 and S34 terminals.

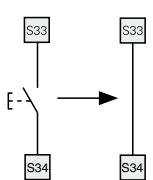

Monitored start

As regards the indicated diagrams, in order to activate the module with the monitored start, it is necessary to remove the connection between S22 and S35 terminals.

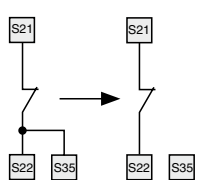

Gate monitoring and safety magnetic sensors.

The safety module can control both emergency stop circuits, gate monitoring circuits or safety magnetic sensors. Replace the emergency stop contacts with switches contacts or with the sensors contacts. The sensors can only be used in the 2-channel configuration.

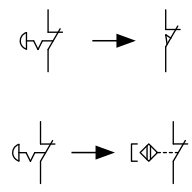

The diagram does not show the exact position of clamps in the product

Application example See page 5/79