

# Autonics

## SCALING METER M4NS/M4YS SERIES

### MANUAL



Thank you very much for selecting Autonics products.  
For your safety, please read the following before using.

#### Caution for your safety

- \*Please keep these instructions and review them before using this unit.
- \*Please observe the cautions that follow:
- Warning** Serious injury may result if instructions are not followed.
- Caution** Product may be damaged, or injury may result if instructions are not followed.
- \*The following is an explanation of the symbols used in the operation manual.
- Caution:** Injury or danger may occur under special conditions.

#### Warning

- In case of using this unit with machineries(Nuclear power control, medical equipment, vehicle, train, airplane, combustion apparatus, entertainment or safety device etc), it requires installing fail-safe device, or contact us for information on type required.  
It may result in serious damage, fire or human injury.

#### Caution

- It must be mounted on panel.  
It may give an electric shock.
- Do not repair, check up or connect when power on and measuring input applied.  
It may give an electric shock.
- Do not disassemble and modify this unit, when it requires. If needs, please contact us.  
It may give an electric shock and cause a fire.
- This unit shall not be used outdoors.  
It might shorten the life cycle of the product or give an electric shock.
- Please observe specification rating.  
It might shorten the life cycle of the product and cause a fire.
- Be sure that there is not insulated between measuring input terminal and power terminal.  
It may cause mechanical trouble of measuring target or result in product damage.
- Please wire properly after check polarity of power.  
It may cause a fire or explosion and result in product damage.
- In cleaning the unit, do not use water or an oil-based detergent.  
It might cause an electric shock or fire that will result in damage to this product.
- Do not use this unit at place where there are flammable or explosive gas, humidity, direct ray the sun, radiant heat, vibration, impact etc.  
It may cause explosion.
- Do not inflow dust or wire dregs into inside of this unit.  
It may cause a fire or mechanical trouble.
- Please connect properly after checking the polarity of measuring terminals.  
It may cause a fire or explosion.

#### Ordering information

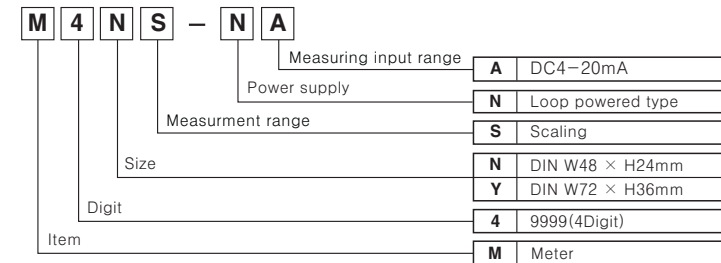

#### Front panel identification

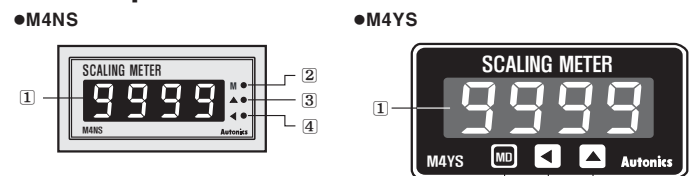

- Display value, Parameter, Error display
  - M, MD Key: When enter into Parameter group, return to RUN mode, After completing Parameter setting
  - ▲, ▲ (Up) key: When enter into the status of Parameter setting
  - ◀, ◀ (Shift) key: When enter into the status of Parameter setting and move Digit
- \*The above specifications are subject to change without notice.

#### Specifications

	M4NS-NA	M4YS-NA
Model	M4NS-NA	M4YS-NA
Power supply	Loop powered type	
Power consumption	-	
Display method	7 Segment LED Display	
Character height	10mm	14mm
Display accuracy *1	F.S. 0.3% rdg ±1Digit	
Display cycle	Selectable 0.5sec/1sec/2sec/3sec/4sec/5sec	
Resolution	12,000 resolution	
Max. display	-1999 to 9999	
Setting type	Setting type with the front keys	
Measuring input range *2	DC4-20mA	
Self-diagnosis function	Error display function	
Insulation resistance	Min. 100MΩ (at 500VDC megger)	
Dielectric strength	2000VAC 50/60Hz for 1 min.	
Vibration	Mechanical	0.75mm amplitude at frequency of 10 ~ 55Hz (for 1 min.) in each X, Y, Z direction for 1 hour
	Malfunction	0.5mm amplitude at frequency of 10 to 55Hz in each X, Y, Z directions for 10 minutes
Shock	Mechanical	300m/s <sup>2</sup> (30G) in X, Y, Z directions for 3 times
	Malfunction	100m/s <sup>2</sup> (10G) in X, Y, Z directions for 3 times
Environ-ment	Ambient temperature	-10 ~ 50°C, Storage temperature: -25 ~ 60°C
	Ambient humidity	35 ~ 85%RH, Storage humidity: 35 ~ 85%RH
Weight	Approx. 44g	Approx. 110g

- \*1: Ambient temperature(25°C ±5°C): F.S. 0.3% rdg of ±1Digit(-10 ~ 50°C: F.S. 0.4% rdg ±1Digit)  
\*2: Impedance between input lines: Max. 600Ω (based on 24VDC)  
Please be aware that activating input power is based on 24VDC, and the recommended impedance also will be lowered if the activating power is lower.  
\*Environment resistance is rated at no freezing or condensation.

#### Dimensions

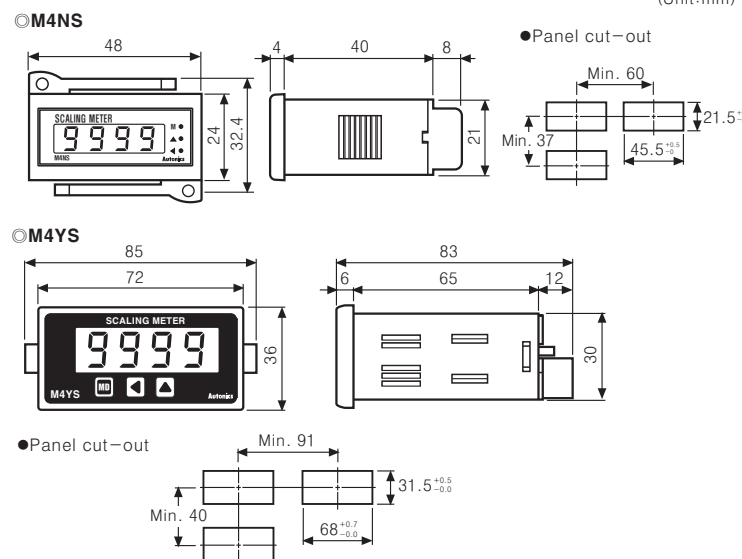

#### Connections

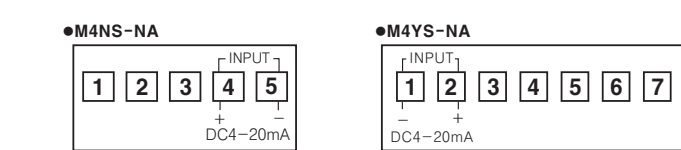

#### Prescale function

This function is to display the value with setting certain Hi/Low limit value against 4-20mADC input. For example If set a=4mADC, b=20mADC and A,B as display value, it will be displayed a=A, b=B.

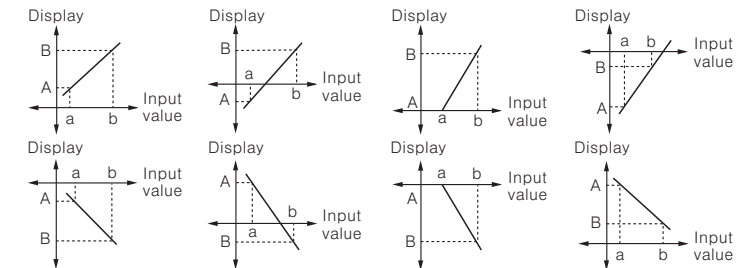

#### Decimal point setting function[dot]

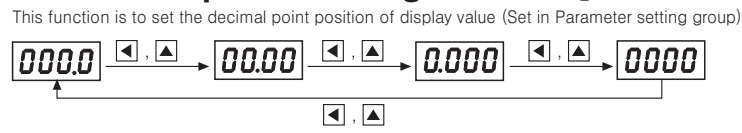

#### Correction function(Parameter group: [InbH],[InbL])

This function is to adjust the error of display value after calculating scale value for measuring input and also correct the input error of sensor etc.  
[InbL]: -100 ~ 100 [Adjust deviation of Low value].  
[InbH]: 0.900 ~ 1.100 [Adjust deviation gradient of high value(%)]  
Ex)When display value is 0.0 to 500.0 against 4-20mA input, if the display value is "1.2" for 4mA input, set -12(ignore the decimal point) as [InbL] value to display "0.0". It is enable to remove offset of Low display value.  
\*When completed above Low value setting then apply 20mA, if the display value is "500.5", the correction value will be 5005/5000=0.999, set 0.999 as [InbH] value then enable to correct High value is 50005 × 0.999 = 50000.  
It is also ignore the decimal point.

#### Display peak value monitoring function

This function is to monitor Max. value and Min. value by current display value then display its Data in [PELH] mode and [PEL] mode.  
Enable to set delay time in [PEL] mode to protect the wrong Data by initial over current and settable from 0 to 30sec. and start to monitor after delay time.

- Pressing MD key to enter Monitoring mode in RUN mode.
- Each Peak value will be shown by pressing ▲ key in Monitoring mode and Peak value will be initialized by pressing ◀ key once more.
- If no key touched for 60sec., it will return to RUN mode.
- When do not use Monitoring function, set [005] for [PEL] in Parameter setting.

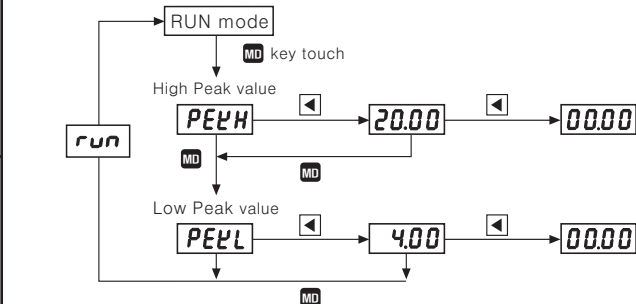

#### Display cycle delay function

It is difficult to display when the measuring input value is fluctuating. In this case it is able to make display value stable by delaying display cycle. Display cycle can be changed in [disE] mode of Parameter 2(Selectable 0.5s/1.0s/2.0s/3.0s/4.0s/5.0s). If select 5.0s, it will be the measuring input value on an average for 5sec., then display it every 5sec.

#### Error Display function

- Error display
  - When [LLLL] display
    - Input current is lower than 3% in 4-20mADC(16mA scale) [LLLL] will display when it is under 3.52mA [16mA × 3% = 0.48mA] → 4mA - 0.48mA = 3.52mA
    - When it is beyond Min. display value(-1999)[by display value]
  - When [HHHH] display
    - Input current is higher than 3% in 4-20mADC(16mA scale) [HHHH] display [16mA × 3% = 0.48mA] → 20mA + 0.48mA = 20.48mA. When it is higher than 20.48mA.
    - When it is beyond Max. display value(9999)[by display value]
- Turn Error display off  
[LLLL] and [HHHH] are displayed when input is out of measuring range, therefore it will be disappeared automatically when input returns to measuring range.
- Error setting and sort  
It will display the error message according to the setting value which set % value against analog input range and set it in [E.PCL] mode by ◀, ▲ key.

[E.PCL] Mode	Error description
0	[LLLL], [HHHH] are displayed when it is over 0% out DC4-20mA range
1	[LLLL], [HHHH] are displayed when it is over 1% out DC4-20mA range
2	[LLLL], [HHHH] are displayed when it is over 2% out DC4-20mA range
3	[LLLL], [HHHH] are displayed when it is over 3% out DC4-20mA range
4	[L-SC], [H-SC] are displayed always when it is out DC4-20mA range

#### Parameter

Parameter	Function	Setting range
L-SC (Low Scale)	Low limit display value for 4mA input	-1.999 ~ 9.999 -19.99 ~ 99.99
H-SC (High Scale)	High limit display value for 20mA input	-199.9 ~ 999.9
dot (Dot)	Set Decimal point position	-1999 ~ 9999
InbL (Input bias low)	Input correction of low limit value(Digit)	-100 ~ 100
InbH (Input bias high)	Input correction of high limit value(%)	0.900 ~ 1.100
PEL (Peak Time)	See the peak value monitoring delay time	0 ~ 30sec
disE (Display period)	Selectable sampling period(sec)	Selectable 0.5/1.0/2.0/3.0/4.0/5.0
E.PCL (Error %)	Display the measurement input is out of input range	0, 1, 2, 3, 4
LoC (Lock)	Set lock function	Selectable ON, OFF

#### Parameter setting

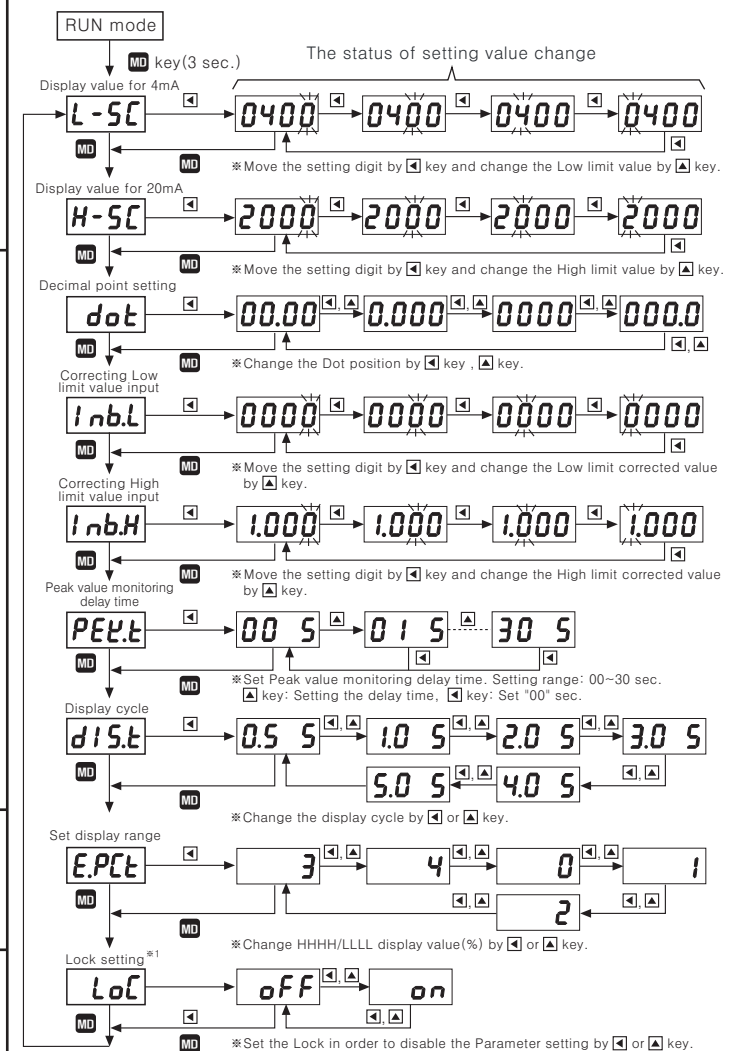

- \*Press MD key to complete the setting and move to next Parameter in status of changing setting value.
- \*Press MD key is pressed for 3 sec. to move to RUN mode after displaying [run].
- \*If any key is untouched for 60 sec., it will return to RUN mode.
- \*1: Lock setting [off]: Able to change or set Parameter.  
[on]: Disable to change or set Parameter but enable to check the setting value in Parameter group. Display to enter into the status of change setting value by pressing ▲, ▲ keys.

#### Factory specification

Parameter display	Factory default	Parameter display	Factory default
L-SC	0400	PEL	015
H-SC	2000	disE	0.55
dot	0000	E.PCL	3
InbL	0000	LoC	off
InbH	1000		

#### Caution for using

- Please use separated line from high voltage line or power line in order to avoid inductive noise.
  - Please use power switch or circuit breaker in order to turn OFF the power.
  - The switch or circuit breaker should be installed near by users for safety.
  - Be sure to avoid using this unit near by machinery makes strong high frequency noise. (Welding machine, high capacity SCR unit etc.)
  - Input line : Shield wire must be used when the measuring input line is getting longer or there are lots of noises.
- \*It may cause malfunction if above instructions are not followed.

#### Major products

- Proximity sensors
- Photoelectric sensors
- Fiber optic sensors
- Door/Door side sensors
- Pressure sensors
- Rotary encoders
- Power controllers
- Sensor controllers
- Graphic/Logic panels
- Temperature controllers
- Tachometer/Pulse(Rate) meters
- Temperature/Humidity transducers
- Switching power supplies
- Stepping motors/drivers/motion controllers
- Field network devices
- Laser marking system(CO<sub>2</sub>, Nd:YAG)
- Laser welding/soldering system
- Counters
- Timers
- Area sensors
- Display units
- Panel meters

**Autonics Corporation**  
http://www.autonics.com

**Satisfiable Partner For Factory Automation**

**HEAD QUARTERS :**  
41-5, Yongdang-dong, Yongsan-si, Gyeongnam, 626-847, Korea

**OVERSEAS SALES :**  
Bldg. 402 3rd Fl., Bucheon Techno Park, 193, Yakdae-dong, Wornni-gu, Bucheon-si, Gyeonggi-do, 420-734, Korea  
TEL:82-32-610-2730 / FAX:82-32-329-0728  
E-mail : sales@autonics.com

**The proposal of a product improvement and development : product@autonics.com**