

RKU 418 RM/WM

Retro-reflective ultrasonic sensor

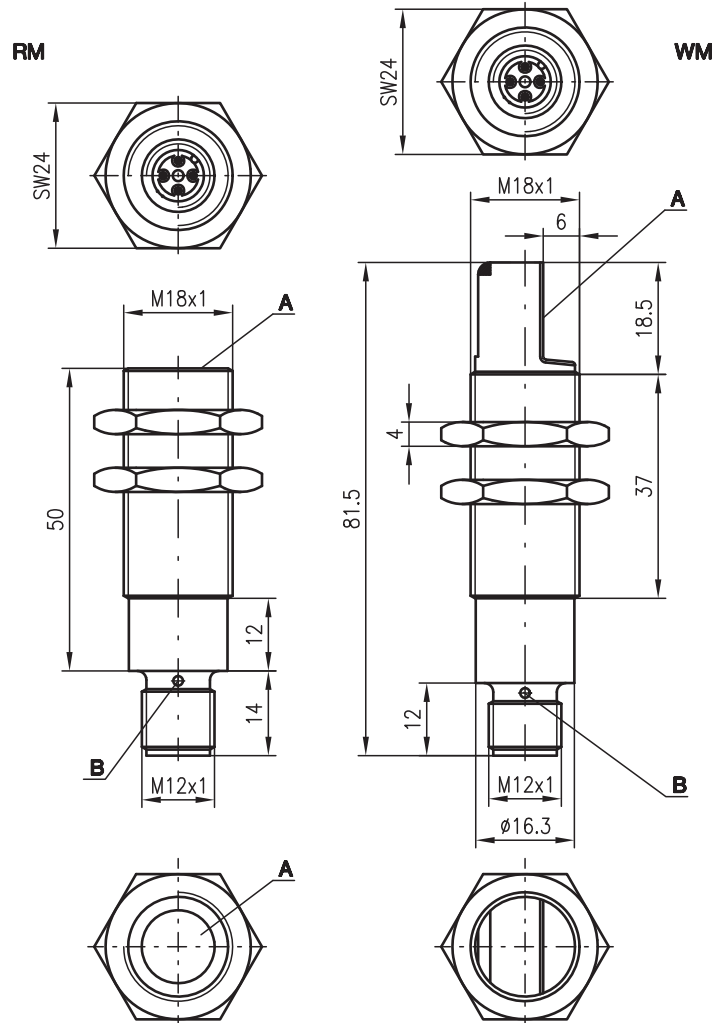

Dimensioned drawing



A Active surface
B Indicator diode Q1



0 ... 200mm
0 ... 700mm



- Colour and transmission independent detection of objects
- Switching behaviour largely independent of surface properties
- No dead zone
- Distance teachable
- Small construction

Electrical connection

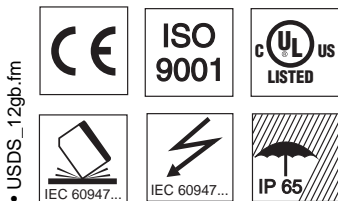
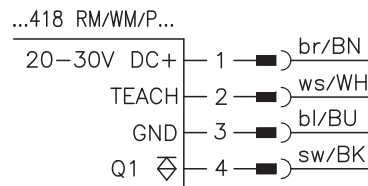

Accessories:

(available separately)

- Mounting systems
- Cable with M12 connector (K-D ...)

We reserve the right to make changes • USDS_12gb_fm

Specifications

Ultrasonic specifications

Operating range ¹⁾
Adjustment range
Dead zone

Ultrasonic frequency
Typ. opening angle
Direction of beam

Temperature drift

Timing

Switching frequency
Response time
Delay before start-up

Electrical data

Operating voltage U_B
Residual ripple
Bias current
Switching output
Function characteristics
Output current
Switching range adjustment

Indicators

Yellow LED
Flashing yellow LED

Mechanical data

Housing
Weight
Connection type

Environmental data

Ambient temp. (operation/storage)
Protective circuit ²⁾
VDE safety class
Protection class
Standards applied
Fitting position

RKU 418 ...-200-S12

0 ... 200mm
120 ... 220mm
≤ 20mm in front of reflector surface
400kHz
see diagrams
RKU 418RM/P...: straight,
RKU 418WM/P...: angular, 90°
± 0.17%/K

RKU 418 ...-700-S12

0 ... 700mm
350 ... 750mm
≤ 50mm in front of reflector surface
200kHz

10Hz
50ms
20ms

5Hz
100ms

20 ... 30V DC (incl. ± 10% residual ripple)
± 10% of U_B
≤ 20mA
PNP transistor
switching in case of object recognition
150mA
teach-in, teach input (pin 2) connected to GND for ≥ 3s

output activated
teaching procedure

metal / CuZn
50g
M12 connector, plastic, 4-pin

-25°C ... +70°C/-40°C ... +85°C
1, 2, 3
III
IP 65
IEC 60947-5-2
any

1) For the complete temperature range, measured object ≥ 20x20mm
2) 1=short-circuit and overload protection, 2=polarity reversal protection, 3=wire break and inductive protection

Order guide

| | Designation | Part No. |
|---|--------------------------|-----------|
| Range: 0 ... 200mm, direction of beam: straight | RKU 418RM/P-5020-200-S12 | 500 38637 |
| Range: 0 ... 200mm, direction of beam: 90° | RKU 418WM/P-5020-200-S12 | 500 38638 |
| Range: 0 ... 700mm, direction of beam: straight | RKU 418RM/P-3020-700-S12 | 500 38641 |
| Range: 0 ... 700mm, direction of beam: 90° | RKU 418WM/P-3020-700-S12 | 500 38642 |

Tables

Diagrams

RKU 418 ...-200-S12

Typ. response behaviour (object 20x20mm)

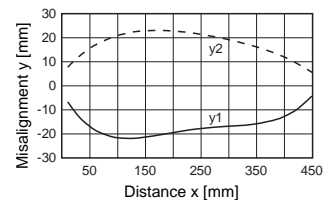

RKU 418 ...-700-S12

Typ. response behaviour (object 20x20mm)

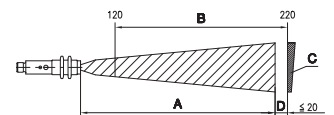
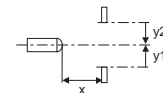
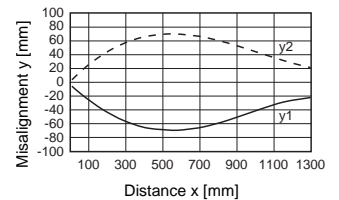

- A Operating range
- B Adjustment range
- C Reflector
- D Dead zone

Remarks

- **Approved purpose:**
The retro-reflective ultrasonic sensors are ultrasonic sensors for acoustic, contactless detection of objects.
- **Teaching procedure:**
Position reflector at the desired switching distance. Connect teach input (pin 2) to GND for ≥ 3s. Reconnect teach input to + U_B or leave unconnected; switching output is taught.
- **Temperature drift**
± 0.17%/K

HRTU 418 RM/WM

Ultrasonic sensors



Dimensioned drawing

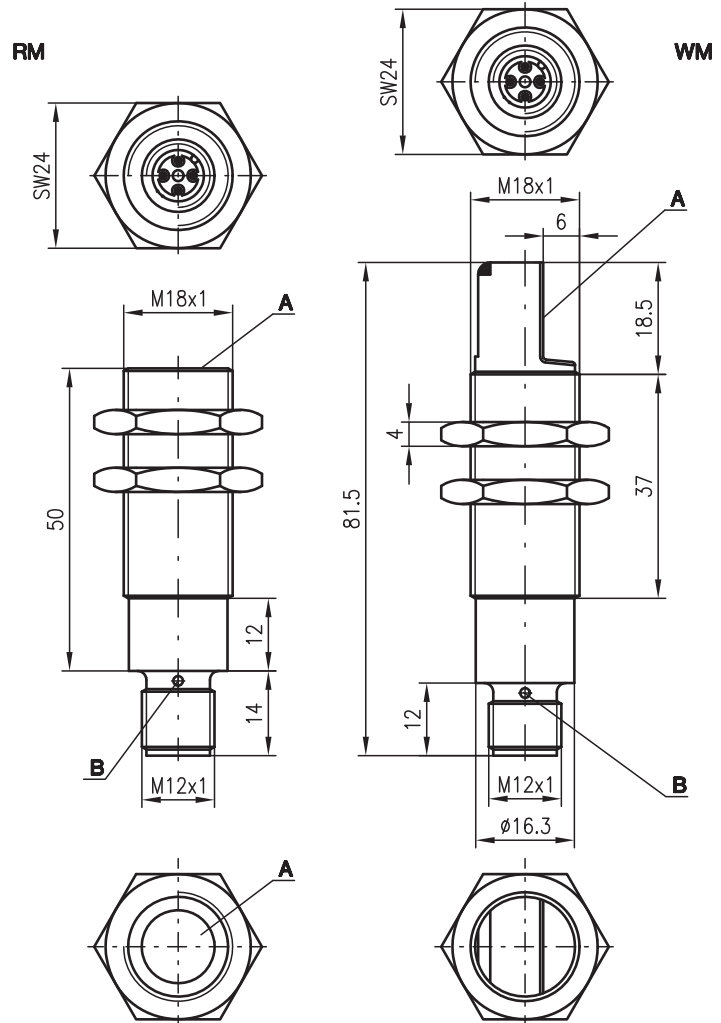

A Active surface
B Indicator diode Q1

Electrical connection

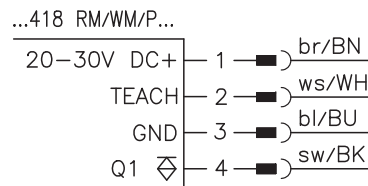

30 ... 200mm
100 ... 700mm



- Colour and transmission independent detection of objects
- Switching behaviour largely independent of surface properties
- Distance teachable
- Small construction

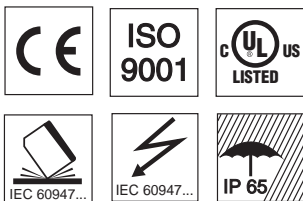

Accessories:

(available separately)

- Mounting systems
- Cable with M12 connector (K-D ...)

We reserve the right to make changes • USDS_10gb.fm

Specifications

Ultrasonic specifications

Operating range ¹⁾
 Adjustment range
 Ultrasonic frequency
 Typ. opening angle
 Resolution
 Direction of beam

HRTU 418...-200-S12

30 ... 200mm
 50 ... 200mm
 400kHz
 see diagrams
 1mm
 HRTU 418RM/P...: straight,
 HRTU 418WM/P...: angular, 90°
 ± 1mm
 10mm
 ± 0.17%/K

HRTU 418...-700-S12

100 ... 700mm
 150 ... 700mm
 200kHz

Reproducibility
 Switching hysteresis
 Temperature drift

Timing

Switching frequency
 Response time
 Delay before start-up

10Hz
 50ms
 20ms

5Hz
 100ms

Electrical data

Operating voltage U_B
 Residual ripple
 Bias current
 Switching output
 Function characteristics
 Output current
 Switching range adjustment

20 ... 30V DC (incl. ± 10% residual ripple)
 ± 10% of U_B
 ≤ 20mA
 PNP transistor
 switching in case of object recognition
 150mA
 teach-in, teach input (pin 2) connected to GND for ≥ 3s

Indicators

Yellow LED
 Flashing yellow LED

output activated
 teaching procedure

Mechanical data

Housing
 Weight
 Connection type

metal / CuZn
 50g
 M12 connector, plastic, 4-pin

Environmental data

Ambient temp. (operation/storage)
 Protective circuit ²⁾
 VDE safety class
 Protection class
 Standards applied
 Fitting position

-25°C ... +70°C/-40°C ... +85°C
 1, 2, 3
 III
 IP 65
 IEC 60947-5-2
 any

1) For the complete temperature range, measured object ≥ 20x20mm
 2) 1=short-circuit and overload protection, 2=polarity reversal protection, 3=wire break and inductive protection

Order guide

| | Designation | Part No. |
|--|---------------------------|-----------------|
| Operating range: 30 ... 200mm, direction of beam: straight | HRTU 418RM/P-5020-200-S12 | 500 38635 |
| Operating range: 30 ... 200mm, direction of beam: 90° | HRTU 418WM/P-5020-200-S12 | 500 38636 |
| Operating range: 100 ... 700mm, direction of beam: straight | HRTU 418RM/P-3020-700-S12 | 500 38639 |
| Operating range: 100 ... 700mm, direction of beam: 90° | HRTU 418WM/P-3020-700-S12 | 500 38640 |

Tables

Diagrams

HRTU 418 ...-200-S12

Typ. response behaviour (object 20x20mm)

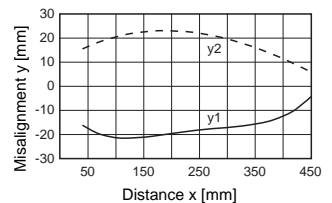

HRTU 418 ...-700-S12

Typ. response behaviour (object 20x20mm)

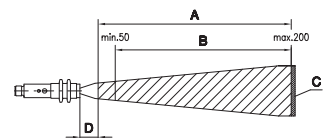
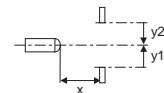
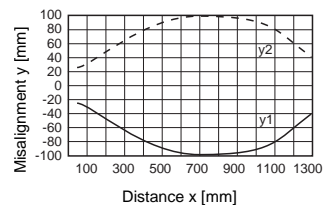

- A Operating range
- B Adjustment range
- C Object
- D Dead zone

Remarks

- **Approved purpose:**
The ultrasonic sensors are used for acoustic, contactless detection of objects.
- **Teaching procedure:**
Position measured object at the desired measurement distance. Connect teach input (pin 2) to GND for ≥ 3s. Reconnect teach input to + U_B or leave unconnected; switching output is taught.
- **Temperature drift**
± 0.17%/K

HRTU 418

Ultrasonic distance sensors



Dimensioned drawing

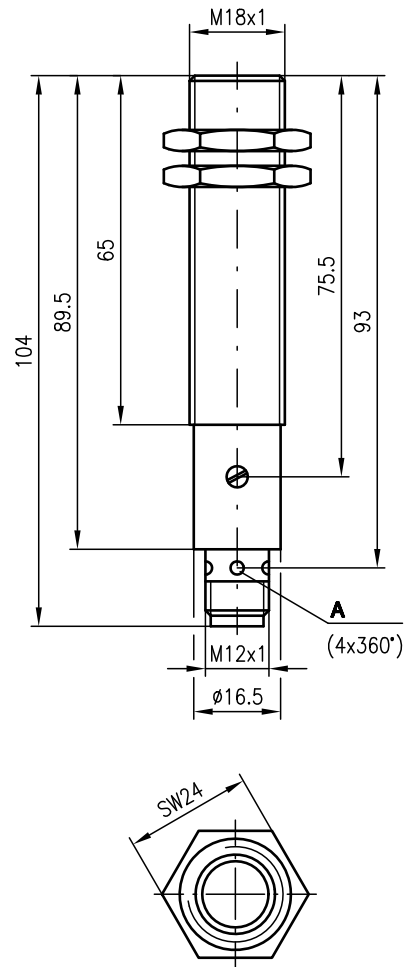

A Indicator diodes Q1



50 ... 300mm
150 ... 1000mm

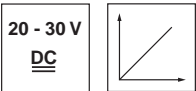

- Ideal for detection of levels of liquids, bulk materials, transparent media, ...
- Distance information largely independent of surface properties
- PC-configuration software for configuring sensor and analogue output
- Up to 10 devices can be synchronised via the SYNC input

Electrical connection

...418 M/V 3010...
...418 M/V 5010...

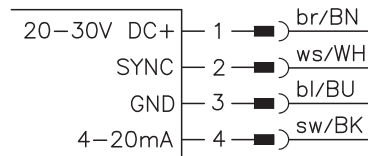

...418 M/V 3310...
...418 M/V 5310...

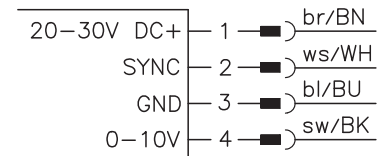

Accessories:

(available separately)

- Mounting systems
- Cable with M12 connector (K-D ...)
- "USDS-Config" configuration software (free download from www.leuze.com)
- PGU 01 (programming unit)

We reserve the right to make changes • USDS_02gb.fm

Specifications

Ultrasonic specifications

| | HRTU...-5x10-300... | HRTU...-3x10-1000... |
|-------------------------------|---|----------------------|
| Operating range ¹⁾ | 50 ... 300mm | 150 ... 1000mm |
| Ultrasonic frequency | 400kHz | 200kHz |
| Opening angle | 6° | |
| Resolution | 1mm | |
| Absolute measurement accuracy | ± 2.5% of the measurement range end value | |
| Reproducibility | ± 1mm | ± 2mm |
| Switching hysteresis | 10mm | 10mm |

Timing

| | 5Hz | 4Hz |
|--|-------|-------|
| Switching frequency (min.) ²⁾ | 5Hz | 4Hz |
| Response time (max.) ²⁾ | 100ms | 120ms |
| Delay before start-up | 280ms | 280ms |

Electrical data

| | |
|-------------------------|---|
| Operating voltage U_B | 20 ... 30V DC (incl. ± 10% residual ripple) |
| Residual ripple | ± 10% of U_B |
| Bias current | ≤ 60mA |
| Switching output | analogue |
| Current output | only HRTU...-x010-... |
| Output current | 4 ... 20mA |
| Load resistor | $R_L = 0 \dots 300\Omega$ |
| Characteristic curve | ascending |
| Voltage output | only HRTU...-x310-... |
| Output voltage | 0 ... 10V |
| Load resistor | $R_L \geq 500\Omega$ |
| Characteristic curve | ascending |

Indicators

| | |
|------------|-----------------|
| Yellow LED | object detected |
|------------|-----------------|

Mechanical data

| | |
|-----------------|-------------------------------|
| Housing | metal / CuZn |
| Weight | 50g |
| Connection type | M12 connector, plastic, 4-pin |

Environmental data

| | |
|-----------------------------------|---------------------------------|
| Ambient temp. (operation/storage) | -25°C ... +70°C/-40°C ... +85°C |
| Protective circuit ³⁾ | 1, 2, 3 |
| VDE safety class | III |
| Protection class | IP 67 |
| Standards applied | IEC 60947-5-2 |
| Fitting position | any |

- 1) For the complete temperature range, measured object $\geq 10 \times 10 \text{mm}$
- 2) Can be configured up to 3 times faster using "USDS-Config"
- 3) 1=short-circuit and overload protection, 2=no polarity reversal protection, 3=wire break and inductive protection

Remarks

- **Approved purpose:**
The ultrasonic distance sensors are used for acoustic, contactless detection of objects.

Order guide

| | Designation | Part No. |
|----------------|---------------------------|-----------|
| Current output | HRTU 418M/V-5010-300-S12 | 500 36259 |
| Current output | HRTU 418M/V-3010-1000-S12 | 500 36260 |
| Voltage output | HRTU 418M/V-5310-300-S12 | 500 40616 |
| Voltage output | HRTU 418M/V-3310-1000-S12 | 500 40618 |

Tables

Diagrams

HRTU...-5x10-300...

Typ. response behaviour (object 10x10mm)

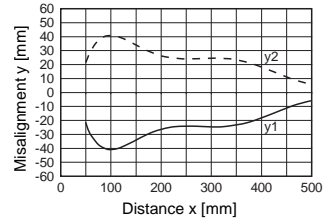

HRTU...-3x10-1000...

Typ. response behaviour (object 10x10mm)

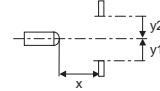
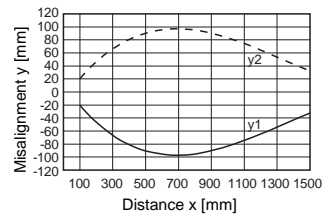

Remarks

- **Synchronisation:**
Mutual interference is excluded by connecting the sensors with the SYNC input.

Configuration software "USDS-Config"

The configuration software runs under Windows 95/98/NT/2000/XP and offers the following features:

- Configuration of multiplex operation
- Configuration of the sensor (attenuation, switching frequency, response time)
- Adjustment of the switching output (start/end of switching range, hysteresis, object present yes/no)
- Adjustment of the analogue output
- Support of various languages



Dimensioned drawing

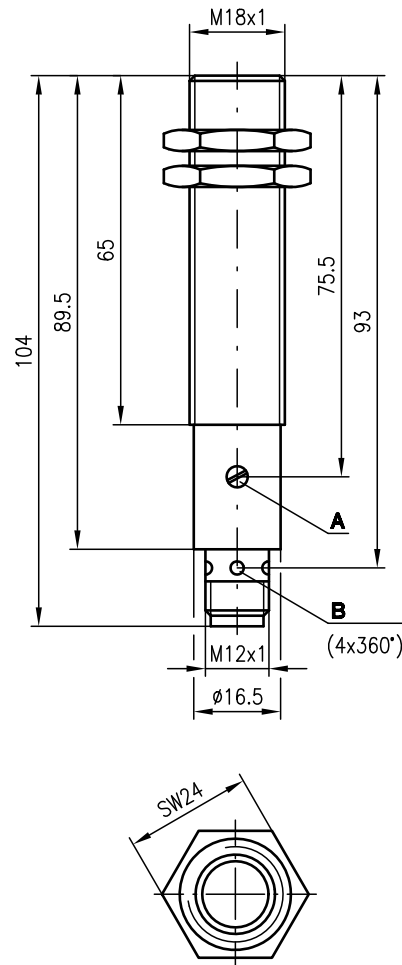

- A End of switching range (only for ... 418M/P ...)
- B Indicator diodes Q1

Electrical connection

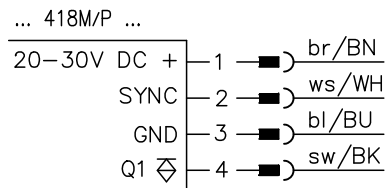

50 ... 300 mm
150 ... 1000 mm



- Ideal for detection of levels of liquids, bulk materials, transparent media, ...
- Distance information largely independent of surface properties
- PC-configuration software for configuring sensor and switching output
- Up to 10 devices can be synchronised via the SYNC input
- Start and end of switching range adjustable separately via PC



Accessories:

(available separately)

- Mounting systems
- Cable with M12 connector (K-D ...)
- "USDS-Config" configuration software (free download from www.leuze.com)
- PGU 01 (programming unit)

We reserve the right to make changes • USDS_01gb.fm

Specifications

Ultrasonic specifications

| | HRTU...-5010-300... | HRTU...-3010-1000... |
|-------------------------------|---|-----------------------------|
| Operating range ¹⁾ | 50 ... 300mm | 150 ... 1000mm |
| Ultrasonic frequency | 400kHz | 200kHz |
| Opening angle | 6° | |
| Resolution | 1 mm | |
| Absolute measurement accuracy | ± 2.5% of the measurement range end value | |
| Reproducibility | ± 1mm | ± 2mm |
| Switching hysteresis | 10mm | 10mm |

Timing

| | HRTU...-5010-300... | HRTU...-3010-1000... |
|--|----------------------------|-----------------------------|
| Switching frequency (min.) ²⁾ | 5Hz | 4Hz |
| Response time (max.) ²⁾ | 100ms | 120ms |
| Delay before start-up | 280ms | 280ms |

Electrical data

| | |
|----------------------------|---|
| Operating voltage U_B | 20 ... 30V DC (incl. ± 10% residual ripple) |
| Residual ripple | ± 10% of U_B |
| Bias current | ≤ 60mA |
| Switching output | PNP transistor |
| Function characteristics | switching in case of object recognition |
| Output current | 150mA |
| Switching range adjustment | potentiometer 270° |

Indicators

| | |
|------------|------------------|
| Yellow LED | output activated |
|------------|------------------|

Mechanical data

| | |
|-----------------|-------------------------------|
| Housing | metal / CuZn |
| Weight | 50g |
| Connection type | M12 connector, plastic, 4-pin |

Environmental data

| | |
|-----------------------------------|---------------------------------|
| Ambient temp. (operation/storage) | -25°C ... +70°C/-40°C ... +85°C |
| Protective circuit ³⁾ | 1, 2, 3 |
| VDE safety class | III |
| Protection class | IP 67 |
| Standards applied | IEC 60947-5-2 |
| Fitting position | any |

1) For the complete temperature range, measured object ≥ 10x10mm
 2) Can be configured up to 3 times faster using "USDS-Config"
 3) 1=short-circuit and overload protection, 2=polarity reversal protection, 3=wire break and inductive protection

Remarks

- **Approved purpose:**
The ultrasonic sensors are used for acoustic, contactless detection of objects.

Order guide

| Designation | Part No. |
|---------------------------|-----------------|
| HRTU 418M/P-5010-300-S12 | 500 36257 |
| HRTU 418M/P-3010-1000-S12 | 500 36258 |

Tables

Diagrams

HRTU...-5010-300...

Typ. response behaviour (object 10x10mm)

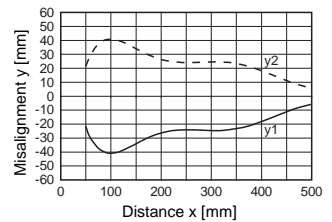

HRTU...-3010-1000...

Typ. response behaviour (object 10x10mm)

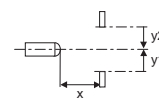
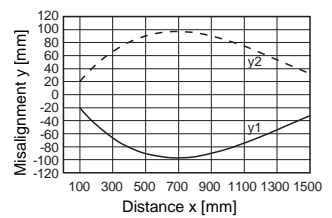

Remarks

- **Synchronisation:**
Mutual interference is excluded by connecting the sensors with the SYNC input.

Configuration software "USDS-Config"

The configuration software runs under Windows 95/98/NT/2000/XP and offers the following features:

- Configuration of multiplex operation
- Configuration of the sensor (attenuation, switching frequency, response time)
- Adjustment of the switching output (start/end of switching range, hysteresis, object present yes/no)
- Adjustment of the analogue output
- Support of various languages

HRTU 418 RM/WM

Ultrasonic sensors

Art. Nr. 50108367



25 ... 400mm
50 ... 700mm



- Colour and transmission independent detection of objects
- Switching behaviour largely independent of surface properties
- Two mutually independent switching points
- Distance teachable
- Small construction

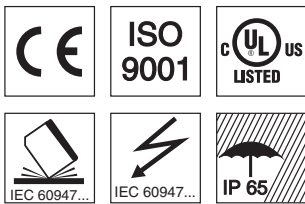

Accessories:

(available separately)

- Mounting systems
- Cable with M12 connector (K-D ...)

Dimensioned drawing

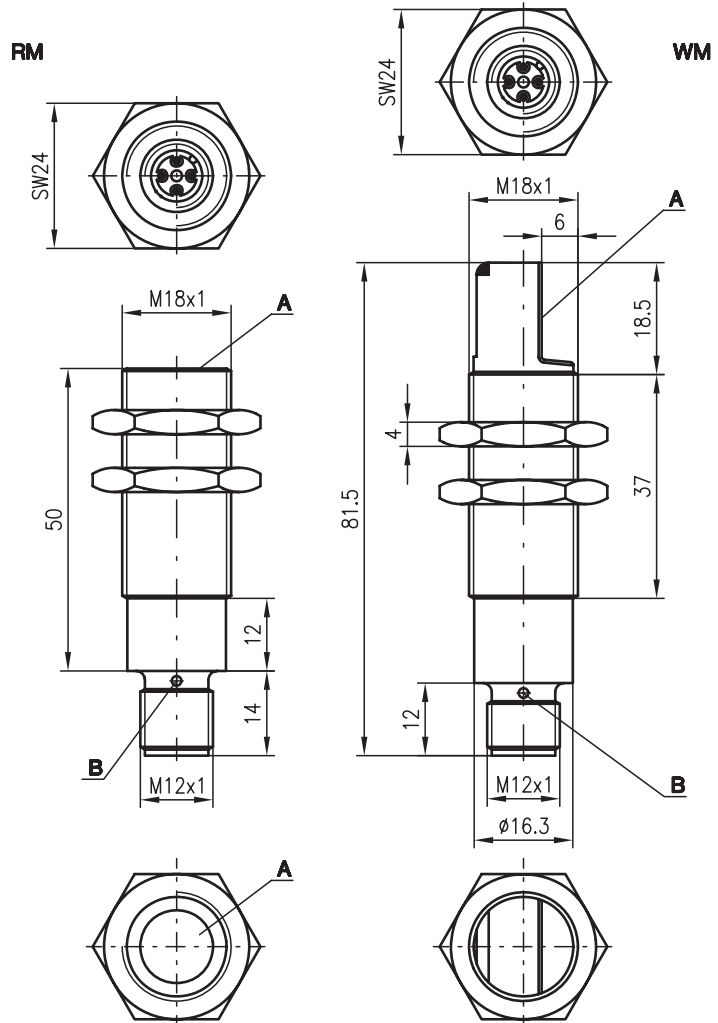

- A** Active surface
- B** Indicator diode Q1, Q2

Electrical connection

| | | |
|-------------|---|--------|
| 20-30V DC + | 1 | br /BN |
| TEACH | 2 | ws /WH |
| GND | 3 | bl /BU |
| Q1 | 4 | sw /BK |
| Q2 | 5 | gr /GY |

We reserve the right to make changes • USDS_13gb.fm

Specifications

Ultrasonic specifications

Operating range ¹⁾
 Adjustment range
 Ultrasonic frequency
 Typ. opening angle
 Resolution
 Direction of beam

Reproducibility
 Switching hysteresis
 Temperature drift

Timing

Switching frequency
 Response time
 Delay before start-up

Electrical data

Operating voltage U_B
 Residual ripple
 Bias current
 Switching output
 Function characteristics
 Output current
 Switching range adjustment

Indicators

Yellow LED
 Flashing yellow LED

Mechanical data

Housing
 Weight
 Connection type

Environmental data

Ambient temp. (operation/storage)
 Protective circuit ²⁾
 VDE safety class
 Protection class
 Standards applied
 Fitting position

HRTU 418 ...-400-S12

25 ... 400mm
 40 ... 400mm
 300kHz
 see diagrams
 1mm
 HRTU 418RM/P...: straight,
 HRTU 418WM/P...: angular, 90°
 ± 1mm
 10mm
 ± 0.17%/K

HRTU 418...-700-S12

50 ... 700mm
 75 ... 700mm
 200kHz

20 ... 30V DC (incl. ± 10% residual ripple)
 ± 10% of U_B
 ≤ 20mA

2x PNP transistor
 switching in case of object recognition
 300mA
 teach-in Q1: teach input (pin 2) connected to GND for
 3 ... 6s
 teach-in Q2: teach input (pin 2) connected to GND for
 6 ... 9s

output Q1, output Q2
 teaching procedure

metal/brass nickel-plated
 50g
 M 12 connector, plastic, 5-pin

-25°C ... +70°C/-40°C ... +85°C
 1, 2, 3
 III
 IP 65
 IEC 60947-5-2
 any

1) For the complete temperature range, measured object ≥ 20x20mm
 2) 1=short-circuit and overload protection, 2=polarity reversal protection, 3=wire break and inductive protection

Tables

Diagrams

HRTU 418 ...-400-S12

Typ. response behaviour (object 20x20mm)

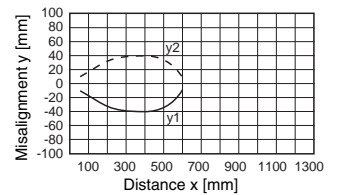

HRTU 418 ...-700-S12

Typ. response behaviour (object 20x20mm)

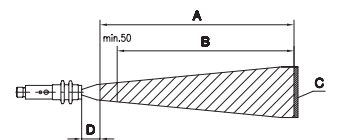
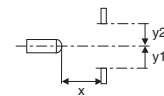
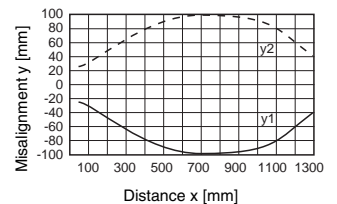

- A Operating range
- B Adjustment range
- C Object
- D Dead zone

Order guide

| | Designation | Part No. |
|---|---------------------------|-----------------|
| Operating range: 25 ... 400mm, direction of beam: straight | HRTU 418RM/P-5220-400-S12 | 501 09016 |
| Operating range: 25 ... 400mm, direction of beam: 90° | HRTU 418WM/P-5220-400-S12 | 501 09017 |
| Operating range: 50 ... 700mm, direction of beam: straight | HRTU 418RM/P-5220-700-S12 | 501 09018 |
| Operating range: 50 ... 700mm, direction of beam: 90° | HRTU 418WM/P-5220-700-S12 | 501 09019 |

Remarks

- **Approved purpose:**
The ultrasonic sensors are used for acoustic, contactless detection of objects.
- **Temperature drift**
± 0.17%/K

Teach-in via input

1. Position measurement object at the desired distance.
2. The respective teach function is activated by applying GND to the teach input (pin 2).
The teach event is signalled by slow flashing of the LEDs.

| Teach function | Teach phase / duration of the teach signal | LED Q1 | LED Q2 |
|---------------------|--|---------|---------|
| Teach preparation | A / 0 ... 3s | off | off |
| switching output Q1 | B / 3 ... 6s | flashes | off |
| switching output Q2 | C / 6 ... 9s | off | flashes |

3. To finish the teach event, disconnect the teach input from GND or switch it to $+U_B$ after the desired time. If the teach event has not completed after 9s, it begins again with phase B.
4. A successful teach event is signalled by the end of the flashing.

Error messages

LEDs which continuously flash fast signal an unsuccessful teach event (sensor not ready):

| LED Q1 | LED Q2 | Error |
|---------------------------|---------------------------|--|
| flashes rapidly | switching state output Q2 | teach switching output Q1 unsuccessful |
| switching state output Q1 | flashes rapidly | teach switching output Q1 unsuccessful |

Remedy:

- Disconnect sensor from voltage to restore the old values.
- Repeat teach event