



LS 412

Throughbeam photoelectric sensors



8m

10 - 30 V
DC

500 Hz

- Throughbeam photoelectric sensors using visible red light
- Slim and short cylindrical metal housing M12x1
- Sensitivity adjustment for optimal adaptation to the application
- Light/dark switching via control line

Dimensioned drawing

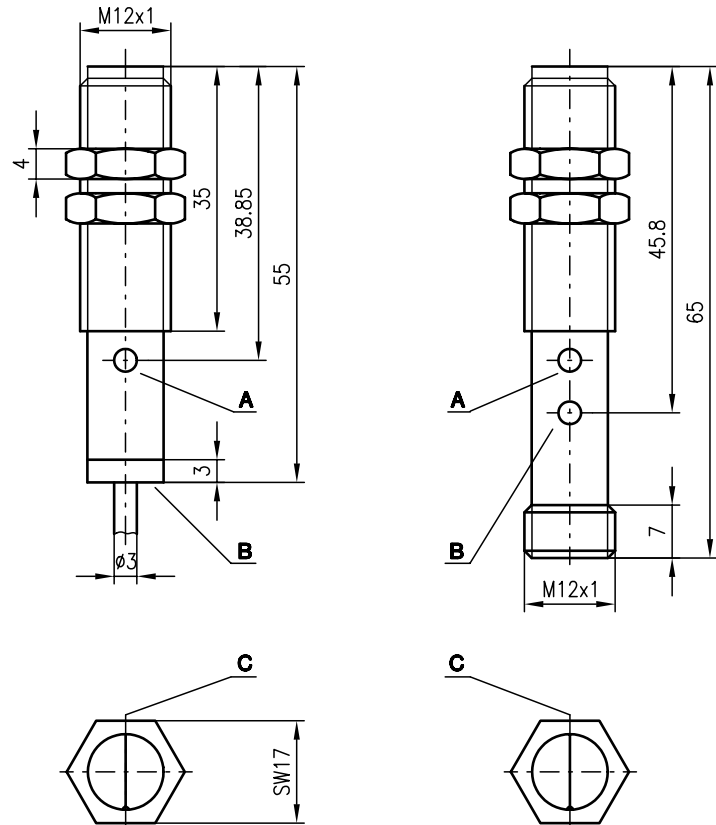

- A Sensitivity adjustment at receiver only
- B Indicator diode
- C Optical axis

Electrical connection

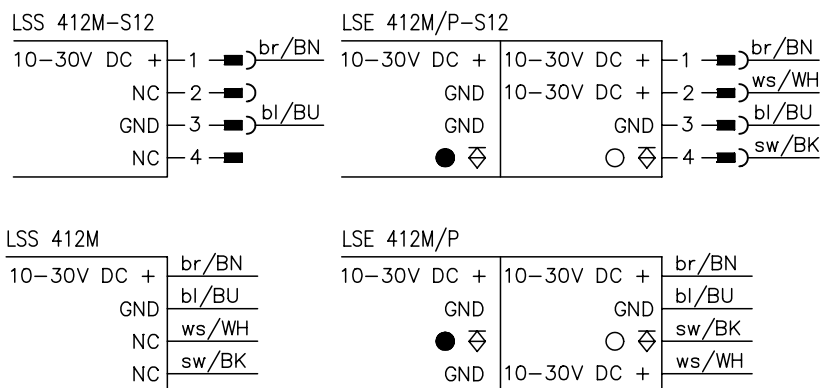

Accessories:

(available separately)

- M12 connectors (KD ...)
- Ready-made cables (KB ...)
- 90° deflection head

We reserve the right to make changes • 412_a01e.fm

Specifications

Optical data

Typ. operating range limit ¹⁾	0 ... 8m
Operating range ²⁾	0 ... 6m
Light source	LED (modulated light)
Wavelength	660nm (visible red light)

Timing

Switching frequency	500Hz
Response time	1 ms
Delay before start-up	≤ 25ms

Electrical data

Operating voltage U_B	10 ... 30VDC (incl. residual ripple)
Residual ripple	≤ 10% of U_B
Bias current	≤ 20mA
Switching output	PNP transistor output
Function characteristics ³⁾	light/dark switching via control line
Signal voltage high/low	≥ ($U_B - 3V$) / ≤ 3V
Output current	max. 200mA
Sensitivity	adjustable

Indicators

LED green (transmitter)	ready
LED yellow (receiver)	switching state

Mechanical data

Housing	nickel-faced brass
Optics cover	plastic
Weight	18g
Connection type	M12 connector 4-pin, cable 2m, 4x0.14mm ²

Environmental data

Ambient temp. (operation/storage)	-25°C ... +55°C / -40°C ... +70°C
Protective circuit ⁴⁾	2, 3
VDE safety class	III
Protection class	IP 67
Standards applied	IEC 60947-5-2

- 1) Typ. operating range limit: max. attainable range without performance reserve
 2) Operating range: recommended range with performance reserve
 3) Light switching for control line (ws/WH): not connected or connected to U_B
 Dark switching for control line (ws/WH): connected to GND
 4) 2=polarity reversal protection, 3=short-circuit protection for all outputs

Order guide

	Designation	Part No.
With M12 connector		
Transmitter and receiver	LS 412M/P-S12	500 81431
With cable connection		
Transmitter and receiver	LS 412M/P	500 81432

Tables

0	6	8
---	---	---

<input type="checkbox"/>	Operating range [m]
<input type="checkbox"/>	Typ. operating range limit [m]

Diagrams

Typ. response behaviour

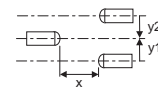
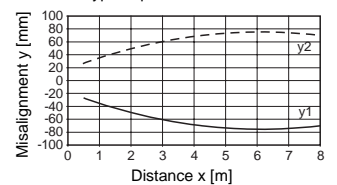

Remarks

- Models with NPN transistor output on request.



PRK 412

Retro-reflective photoelectric sensors with polarisation filter



Dimensioned drawing

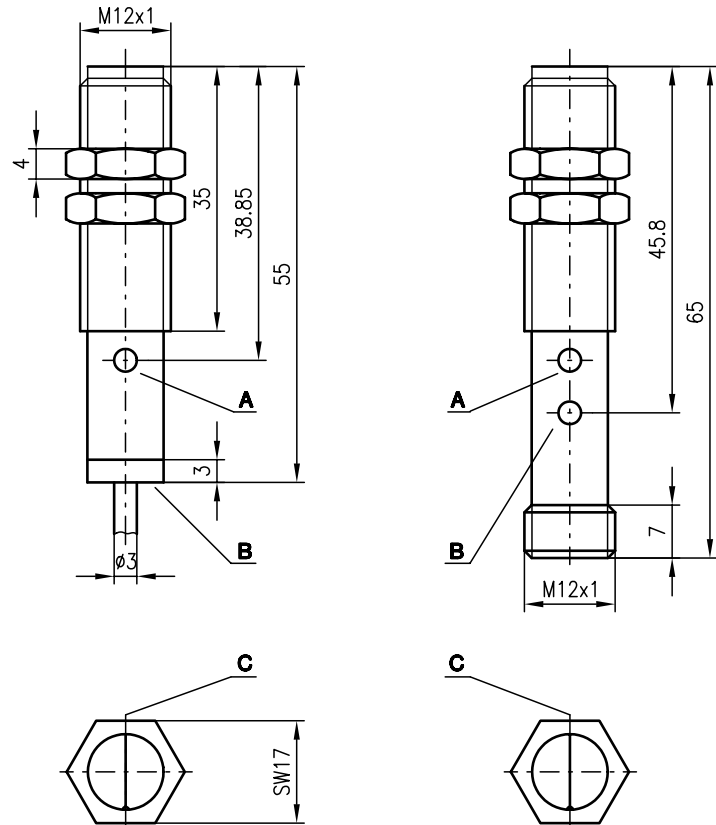

- A Sensitivity adjustment
- B Indicator diode
- C Optical axis

0.05 ... 1.6 m



10 - 30 V
DC

700 Hz

- Retro-reflective photoelectric sensors using visible red light, with polarisation filter
- High switching frequency for detection of fast events
- Slim and short cylindrical metal housing M12x1
- Light/dark switching via control line

Electrical connection

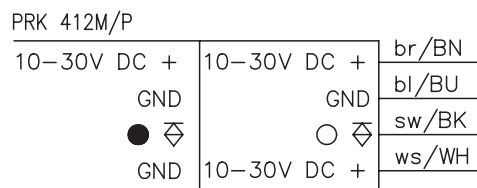

ISO 9001



Accessories:

(available separately)

- M12 connectors (KD ...)
- Ready-made cables (KB ...)
- Reflectors
- Reflective tape
- 90° deflection head

We reserve the right to make changes • 412_b01e.fm



Specifications

Optical data

Typ. operating range limit (TK(S) 100x100) ¹⁾	0.05 ... 1.6m
Operating range ²⁾	see table
Light beam characteristic	divergent
Light source	LED (modulated light)
Wavelength	660nm (visible red light, polarised)

With polarisation filter

Timing

Switching frequency	700Hz
Response time	0.7ms
Delay before start-up	≤ 25ms

Electrical data

Operating voltage U_B	10 ... 30VDC (incl. residual ripple)
Residual ripple	≤ 10% of U_B
Bias current	≤ 20mA
Switching output	PNP transistor output
Function characteristics ³⁾	light/dark switching via control line
Signal voltage high/low	≥ ($U_B - 3V$) / ≤ 3V
Output current	max. 200mA
Sensitivity	adjustable

Indicators

LED yellow	switching state
------------	-----------------

Mechanical data

Housing	nickel-faced brass
Optics cover	plastic
Weight	18g
Connection type	M12 connector 4-pin, cable 2m, 4x0.14mm ²

Environmental data

Ambient temp. (operation/storage)	-25°C ... +55°C / -40°C ... +70°C
Protective circuit ⁴⁾	2, 3
VDE safety class	III
Protection class	IP 67
Standards applied	IEC 60947-5-2

- 1) Typ. operating range limit: max. attainable range without performance reserve
- 2) Operating range: recommended range with performance reserve
- 3) Light switching for control line (ws/WH): not connected or connected to U_B
Dark switching for control line (ws/WH): connected to GND
- 4) 2=polarity reversal protection, 3=short-circuit protection for all outputs

Tables

PRK 412

Reflectors	Operating range
1 TK(S) 100x100	0.15 ... 1.3m
2 MTK(S) 50x50	0.15 ... 0.8m
3 TK(S) 30x50	0.15 ... 0.6m
4 TK(S) 20x40	0.15 ... 0.5m
5 Tape 2 100x100	0.15 ... 0.5m

1	0.05	1.3	1.6
2	0.05	0.8	1.1
3	0.05	0.6	0.8
4	0.05	0.5	0.6
5	0.05	0.5	0.6

- Operating range [m]
- Typ. operating range limit [m]

Diagrams

PRK 412

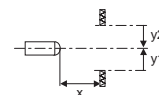
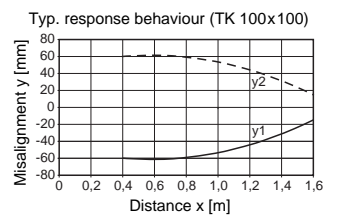

Order guide

	Designation	Part No.
With M12 connector		
With polarisation filter	PRK 412M/P-S12	500 81407
With cable connection		
With polarisation filter	PRK 412M/P	500 81408

Remarks

- Models with NPN transistor output on request.



RT 412

Energetic diffuse reflection light scanners



Dimensioned drawing

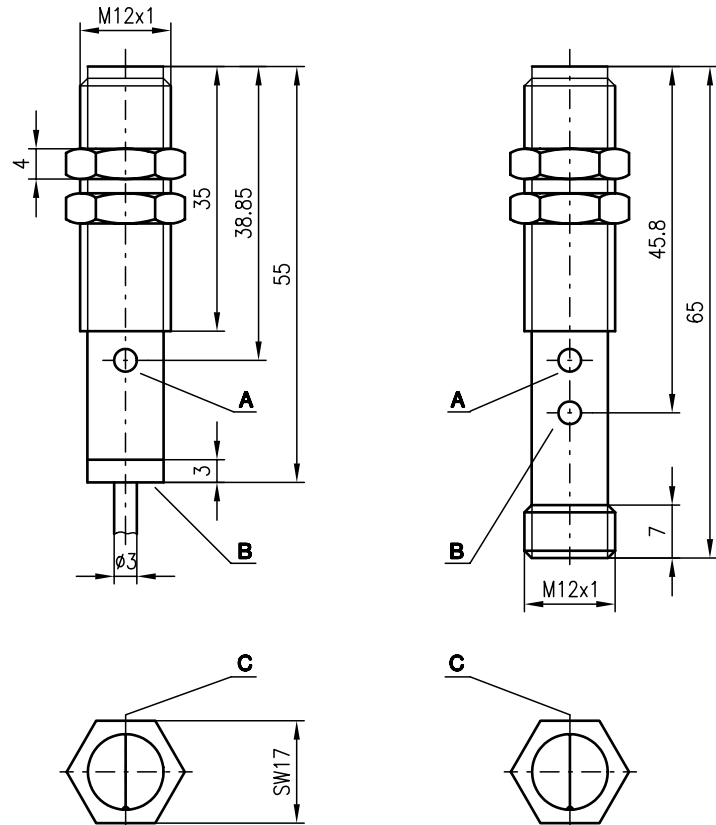

- A Sensitivity adjustment
- B Indicator diode
- C Optical axis

0 ... 400mm



- Energetic diffuse reflection light scanners using visible red light
- Slim and short cylindrical metal housing M12x1
- High switching frequency for detection of fast events
- Light/dark switching via control line

Electrical connection

RT 412M/P-200-S12

10-30V DC +	10-30V DC +	1	br/BN
GND	10-30V DC +	2	ws/WH
GND	GND	3	bl/BU
● ⊕	○ ⊕	4	sw/BK

RT 412M/P-200

10-30V DC +	10-30V DC +	br/BN
GND	GND	bl/BU
● ⊕	○ ⊕	sw/BK
GND	10-30V DC +	ws/WH



Accessories:

(available separately)

- M12 connectors (KD ...)
- Ready-made cables (KB ...)

Specifications

Optical data

Typ. scanning range limit (white 90%) ¹⁾	0 ... 400mm
Scanning range ²⁾	see tables
Adjustment range	50 ... 400mm
Light source	LED (modulated light)
Wavelength	660nm (visible red light, polarised)

Timing

Switching frequency	700Hz
Response time	0.7ms
Delay before start-up	≤ 25ms

Electrical data

Operating voltage U_B	10 ... 30VDC (incl. residual ripple)
Residual ripple	≤ 10% of U_B
Bias current	≤ 20mA
Switching output	PNP transistor output
Function characteristics ³⁾	light/dark switching via control line
Signal voltage high/low	≥ ($U_B - 3V$) / ≤ 3V
Output current	max. 200mA
Sensitivity	adjustable

Indicators

LED yellow	switching state
------------	-----------------

Mechanical data

Housing	nickel-faced brass
Optics cover	plastic
Weight	18g
Connection type	M12 connector 4-pin, cable 2m, 4x0.14mm ²

Environmental data

Ambient temp. (operation/storage)	-25°C ... +55°C / -40°C ... +70°C
Protective circuit ⁴⁾	2, 3
VDE safety class	III
Protection class	IP 67
Standards applied	IEC 60947-5-2

- 1) Typ. scanning range limit: max. attainable range without performance reserve
- 2) Scanning range: recommended range with performance reserve
- 3) Light switching for control line (ws/WH): not connected or connected to U_B
Dark switching for control line (ws/WH): connected to GND
- 4) 2=polarity reversal protection, 3=short-circuit protection for all outputs

Order guide

	Designation	Part No.
With M12 connector	RT 412M/P-200-S12	500 81409
With cable connection	RT 412M/P-200	500 81410

Tables

1	0	200	400
2	2	100	200
3	5	70	140

1	white 90%
2	grey 18%
3	black 6%

<input type="checkbox"/>	Scanning range [mm]
<input type="checkbox"/>	Typ. scanning range limit [mm]

Diagrams

Typ. response behaviour (white 90%)

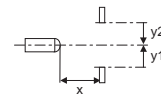
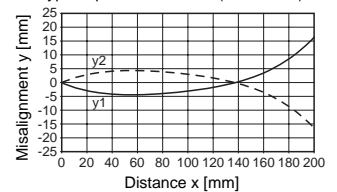

Remarks

- With the set scanning range, a tolerance of the upper and lower scanning range limit is possible depending on the reflection properties of the material surface.
- Models with NPN transistor output on request.